

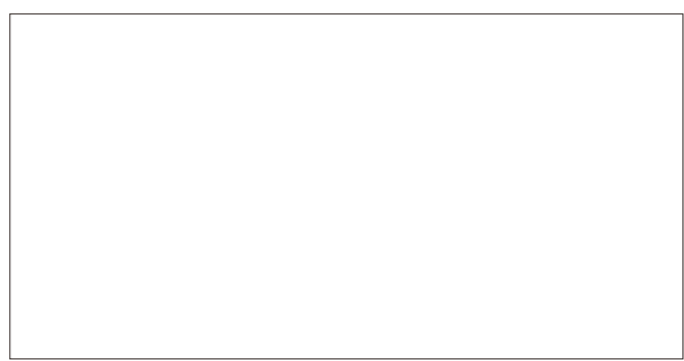

Automatic energy savings,
high performance and
a protected test environment

A-series



IMV CORPORATION

<https://www.imv-global.com/>

*The specifications and design are subject to change without notice.

July 2021

IMV CORPORATION

 Global version

- 02 Features
- 03 A11
- 05 A22
- 07 A30
- 09 A45
- 11 A65
- 13 A74
- 15 Environmental test systems
- 21 Optional units
- 22 Videos
- 23 Technical guidance



01 Improvement in excitation force

When compared with the conventional i & J-series, the A-series has an increased relative excitation force.

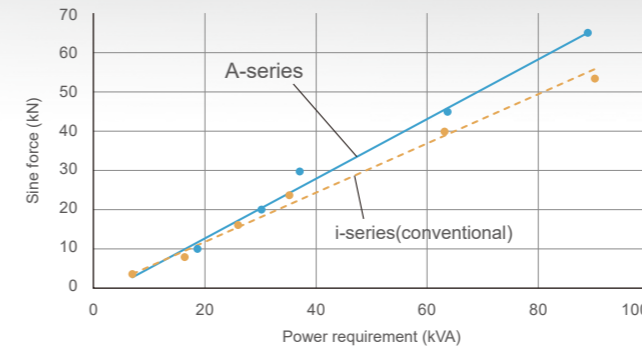

02 Standard 76.2 mmp-p displacement *Only for A30, A45, A65, A74

A-series has a displacement of 76.2 mmp-p (3 inch stroke) which provides a good balance within the specifications for velocity, acceleration and displacement. This single system can be used in a wide variety of tests.



03 Increase in frequency range

In addition to the increased displacement of 76.2 mmp-p, the maximum frequency range is also higher compared to the i- and J-series.

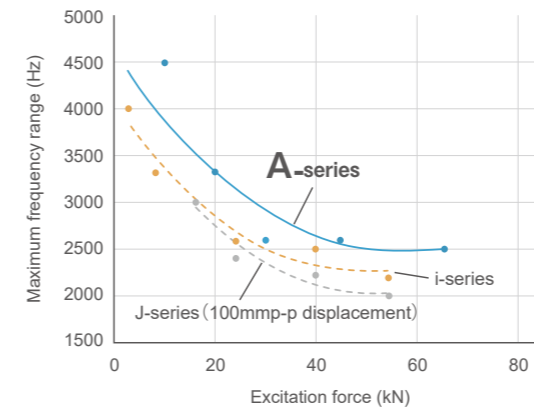

04 Introduction of new power module

By developing a power amplifier that uses a new next-generation silicon carbide power module, IMV has achieved low noise and high efficiency. This new power module is standard equipment for all A-series models.

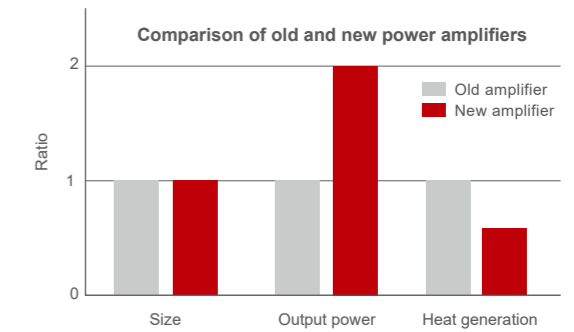

05 High velocity shock testing

Where a test requires a high shock velocity, traditional shaker systems use a matching transformer to achieve the necessary lower field voltage. Since IMV's ECO-system has complete control over the field level, the field value can be adjusted to increase the maximum shock velocity capability of the system. By entering the specified shock profile into IMV's K2 controller, the field level in the shaker is automatically adjusted to ensure that the required velocity is achieved. A-series (EM amplifier model) provides a maximum of 3.5 m/s shock velocity testing.

Examples of shock test

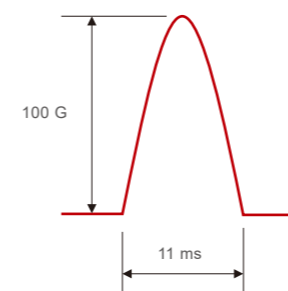

		i220/SA1HAG					
i-series (conventional)	Model	i220/SA1HAG					
	Rated Force Shock (kN)	16					
	Maximum Velocity Shock (m/s)	2.2					
	Maximum Displacement (mmp-p)	51					
	Maximum Load (kg)	Not achievable (not enough velocity and displacement)					
		No applicable product	J230/SA3HAG	J240/SA4HAG	J250/SA6HAG	J260/SA7HAG	No applicable product
J-series (conventional)	Model	No applicable product					
	Rated Force Shock (kN)	—	40	55	80	108	—
	Maximum Velocity Shock (m/s)	—	2.4	2.4	2.4	2.4	—
	Maximum Displacement (mmp-p)	—	100	100	100	100	—
	Maximum Load (kg)	Not achievable (not enough velocity)					
		A11/EM1HAG	A22/EM2HAG	A30/EM3HAG	A45/EM4HAG	A65/EM5HAG	A74/EM8HAG
A-series	Model	A11/EM1HAG A22/EM2HAG A30/EM3HAG A45/EM4HAG A65/EM5HAG A74/EM8HAG					
	Rated Force Shock (kN)	22 (16.5)	44 (36)	60 (50)	90 (80)	130 (120)	180 (160)
	Maximum Velocity Shock (m/s)	2.5 (3.5)	2.5 (3.5)	2.5 (3.5)	2.5 (3.5)	2.5 (3.5)	2.5 (3.5)
	Maximum Displacement (mmp-p)	51 (55)	51 (55)	76.2	76.2	76.2	76.2
	Maximum Load (kg)	5	14	17	30	48	86

*Maximum load on bare table

A11/SA1HAG (Standard) A11/EM1HAG (ECO)

A wider range of test requirements and higher test specifications.



System Model		A11/SA1HAG	A11/EM1HAG	Model	A11
Frequency Range (Hz)		0 - 4500 ^{*4}	0 - 4500 ^{*4}	Armature Mass (kg)	11
Rated Force	Sine (kN)	11	11	Armature Diameter (φmm)	210
	Random (kN rms) ^{*1}	11	11	Allowable Eccentric Moment (N · m)	294
	Shock (kN)	22	22	Dimensions (mm) W × H × D	946 × 827 × 676
	High Velocity Shock (kN)	—	16.5	Shaker Body Diameter (φmm)	585
Maximum Acc.	Sine (m/s ²)	1000	1000	Mass (kg)	1080
	Random (m/s ² rms)	630	630	Model	SA1HAG-A11 EM1HAG-A11
	Shock (m/s ² peak)	2000	2000	Maximum Output (kVA)	12
	High Velocity Shock (m/s ² peak)	—	1500	Dimensions (mm) W × H × D	580 × 1950 × 850
Maximum Vel.	Sine (m/s)	2.0	2.0	Mass (kg)	280 470
	Shock (m/s peak)	2.5	2.5	Controller	Vibration Controller
Maximum Disp.	Sine (mmp-p)	51	51	Cooling Method	Air cooling
	High Velocity Shock (mmp-p)	—	55	Blower	Dimensions (mm) W × H × D ^{*5}
Maximum Travel (mmp-p)	64	64	Mass (kg)		125 140
Maximum Load (kg)	200	200	Wattage (kw)		3.7
Power Requirements (kVA) ^{*2}	20.4	20.4	Duct Hose Diameter (φ)	125	
Breaker Capacity (A) ^{*3}	75	75			

^{*1} Random force ratings are specified in accordance with ISO5344 conditions. Please contact IMV or your local distributor with specific test requirements.
^{*2} Power supply: 3-phase 200/220/380/400/415 V, 50/60 Hz. A transformer is required for other supply voltages.
^{*3} Breaker capacity for AC 200 V.
^{*4} Above 4000 Hz, the force rolls-off at a rate of -6 dB/oct.
^{*5} The specification above applies to 60 Hz. Dimensions change for 50 Hz.
 *The specifications show the maximum system performance. For long-duration tests, system must be de-rated up to 70%.
 Continuous use at maximum levels may cause failure. Please contact IMV if your system operates at more than 70%.
^{*}For random vibration tests, please set the test definition of the peak value of acceleration waveform to operate at less than the maximum acceleration of shock.
^{*}Frequency range values vary according to the sensor and vibration controller.
^{*}Armature mass and acceleration may change when a chamber is added.
^{*}Mass and dimensions may change for CE-marked systems.

System composition

■ Standard equipment ■ Optional items

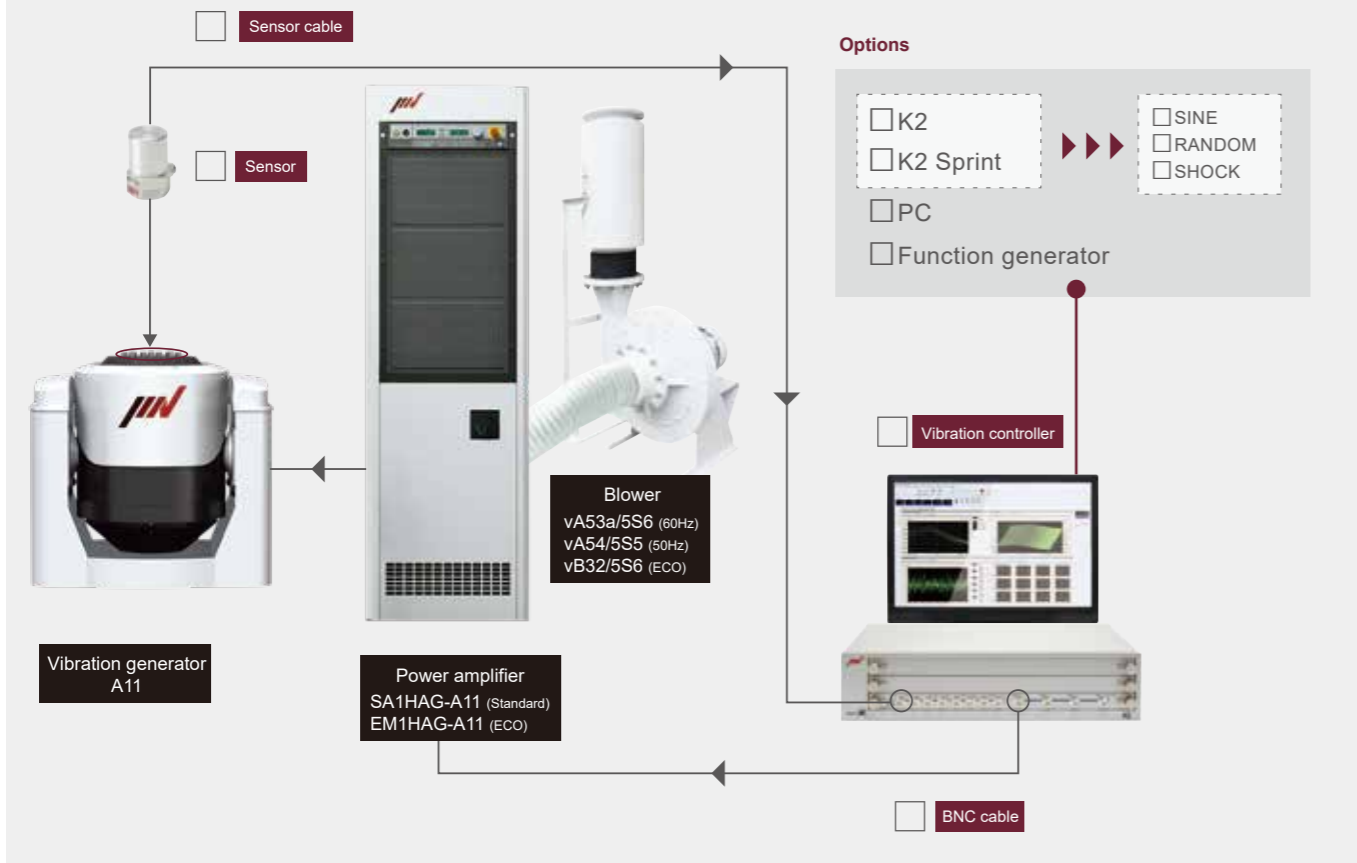

Head expander compatible with A11

Use a head expander for test samples that are too large to put on the table. The test sample mass must fall within the load limit of the shaker (200 kg) minus the head expander mass. When using the head expander, the upper limit frequency is smaller than when using the test system alone.

Model	Dimensions (mm)	Mass (kg)	Maximum frequency (Hz)	Material
<input type="checkbox"/> TBV-315-A11-A	315 × 315 × t 30	8.5	1000	Aluminum alloy
<input type="checkbox"/> TBV-315-A11-M	315 × 315 × t 30	5.8	1000	Magnesium alloy
<input type="checkbox"/> TBV-400-A11-A	400 × 400 × t 30	13	600	Aluminum alloy
<input type="checkbox"/> TBV-400-A11-M	400 × 400 × t 30	9	600	Magnesium alloy
<input type="checkbox"/> TBV-500-A11-A	500 × 500 × t 40	15	500	Aluminum alloy
<input type="checkbox"/> TBV-500-A11-M	500 × 500 × t 40	10.4	500	Magnesium alloy
<input type="checkbox"/> TBV-630-A11-A	630 × 630 × t 45	19	360	Aluminum alloy
<input type="checkbox"/> TBV-630-A11-M	630 × 630 × t 45	12.5	360	Magnesium alloy
<input type="checkbox"/> TBV-800-A11-A	800 × 800 × t 70	45	350	Aluminum alloy
<input type="checkbox"/> TBV-800-A11-M	800 × 800 × t 70	30	350	Magnesium alloy



Slip table compatible with A11

Use a slip table for test samples that are too large to put on the table. The test sample mass must fall within the load limit of the shaker (200 kg) minus the head expander mass. When using the head expander, the upper limit frequency is smaller than when using the test system alone.

MB: Mechanical Bearing

The mechanical bearing uses a linear motion guide which has a component with a linear rolling motion. It contributes substantially to the high performance of the tables with high rigidity, high load, and long stroke motion. Another strong feature of the mechanical bearing is its easy operability, since it is lightweight and has no need for a hydraulic unit.

Model	Dimensions (mm)	Mass (kg)	Maximum frequency (Hz)	Material
<input type="checkbox"/> TBH-550-A11-A-MB	550 × 550 × t 40	55	2000	Aluminum alloy
<input type="checkbox"/> TBH-750-A11-A-MB	750 × 750 × t 40	93	2000	Aluminum alloy
<input type="checkbox"/> TBH-950-A11-A-MB	950 × 950 × t 40	138	1250	Aluminum alloy

^{*}The weight applies to a plate made of aluminum. Please contact us for a plate made of magnesium.



Cubic fixtures compatible with A11

The specimen can be fastened to the top or side face of the cubic fixture where testing in each axis is required. Two types of cubic fixture are available. Type A has mounting holes on each face and Type B has specimen mounting plates which attach to the cubic frame.

Model	Dimensions (mm)	Mass (kg)	Maximum frequency (Hz)	Material
<input type="checkbox"/> TCJ-A150-A11-A	150 × 150 × 150	5.5	2000	Aluminum alloy
<input type="checkbox"/> TCJ-A150-A11-M	150 × 150 × 150	4.0	2000	Magnesium alloy
<input type="checkbox"/> TCJ-A160-A11-A	160 × 160 × 160	6.5	2000	Aluminum alloy
<input type="checkbox"/> TCJ-A160-A11-M	160 × 160 × 160	4.6	2000	Magnesium alloy
<input type="checkbox"/> TCJ-A200-A11-A	200 × 200 × 200	8	1000	Aluminum alloy
<input type="checkbox"/> TCJ-A200-A11-M	200 × 200 × 200	5.6	1000	Magnesium alloy
<input type="checkbox"/> TCJ-B150-A11-A	150 × 150 × 150	3.5	2000	Aluminum alloy
<input type="checkbox"/> TCJ-B150-A11-M	150 × 150 × 150	2.5	2000	Magnesium alloy
<input type="checkbox"/> TCJ-B160-A11-A	160 × 160 × 160	4.0	2000	Aluminum alloy
<input type="checkbox"/> TCJ-B160-A11-M	160 × 160 × 160	2.8	2000	Magnesium alloy
<input type="checkbox"/> TCJ-B200-A11-A	200 × 200 × 200	10	2000	Aluminum alloy
<input type="checkbox"/> TCJ-B200-A11-M	200 × 200 × 200	7	2000	Magnesium alloy

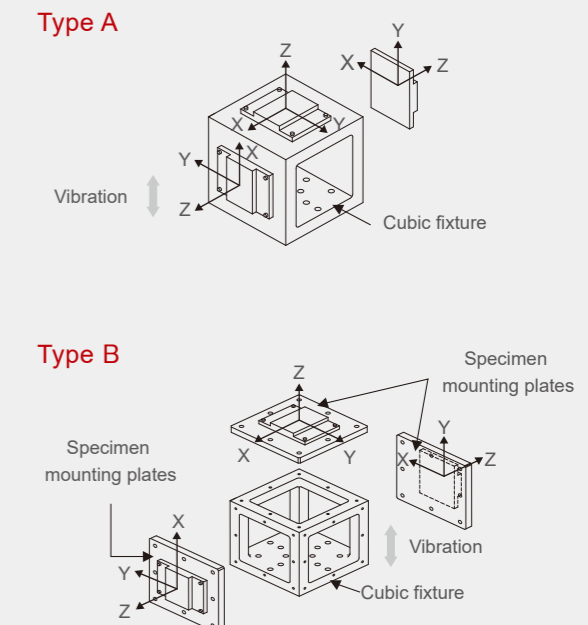

A22/SA2HAG (Standard) A22/EM2HAG (ECO)

A wider range of test requirements and higher test specifications.



System Model		A22/SA2HAG	A22/EM2HAG	Model	A22
Frequency Range (Hz)		0 - 3300	0 - 3300	Armature Mass (kg)	22
Rated Force	Sine (kN)	22	22	Armature Diameter (φmm)	280
	Random (kN rms)*1	22	22	Allowable Eccentric Moment (N · m)	700
	Shock (kN)	44	44	Dimensions (mm) W × H × D	1038 × 955 × 775
	High Velocity Shock (kN)	—	36	Shaker Body Diameter (φmm)	678
Maximum Acc.	Sine (m/s ²)	1000	1000	Mass (kg)	1600
	Random (m/s ² rms)	630	630	Model	SA2HAG-A22 EM2HAG-A22
	Shock (m/s ² peak)	2000	2000	Maximum Output (kVA)	24
	High Velocity Shock (m/s ² peak)	—	1636	Dimensions (mm) W × H × D	580 × 1950 × 850
Maximum Vel.	Sine (m/s)	2.0	2.0	Mass (kg)	350 560
	Shock (m/s peak)	2.5	2.5	Controller	Vibration Controller
Maximum Disp.	Sine (mmp-p)	51	51	Cooling Method	Air cooling
	High Velocity Shock (mmp-p)	—	55	Blower	Dimensions (mm) W × H × D*4
Maximum Travel (mmp-p)		64	64	Mass (kg)	210
Maximum Load (kg)		300	300	Wattage (kw)	5.5
Power Requirements (kVA)*2		30	30	Duct Hose Diameter (φ)	200
Breaker Capacity (A)*3		100	100		

*1 Random force ratings are specified in accordance with ISO5344 conditions. Please contact IMV or your local distributor with specific test requirements.
 *2 Power supply: 3-phase 200/220/380/400/415 V, 50/60 Hz. A transformer is required for other supply voltages.
 *3 Breaker capacity for AC 200 V.
 *4 The specification above applies to 60 Hz. Dimensions change for 50 Hz.
 *The specifications show the maximum system performance. For long-duration tests, system must be de-rated up to 70%. Continuous use at maximum levels may cause failure. Please contact IMV if your system operates at more than 70%.
 *For random vibration tests, please set the test definition of the peak value of acceleration waveform to operate at less than the maximum acceleration of shock.
 *Frequency range values vary according to the sensor and vibration controller.
 *Armature mass and acceleration may change when a chamber is added.
 *Mass and dimensions may change for CE-marked systems.

System composition

■ Standard equipment ■ Optional items

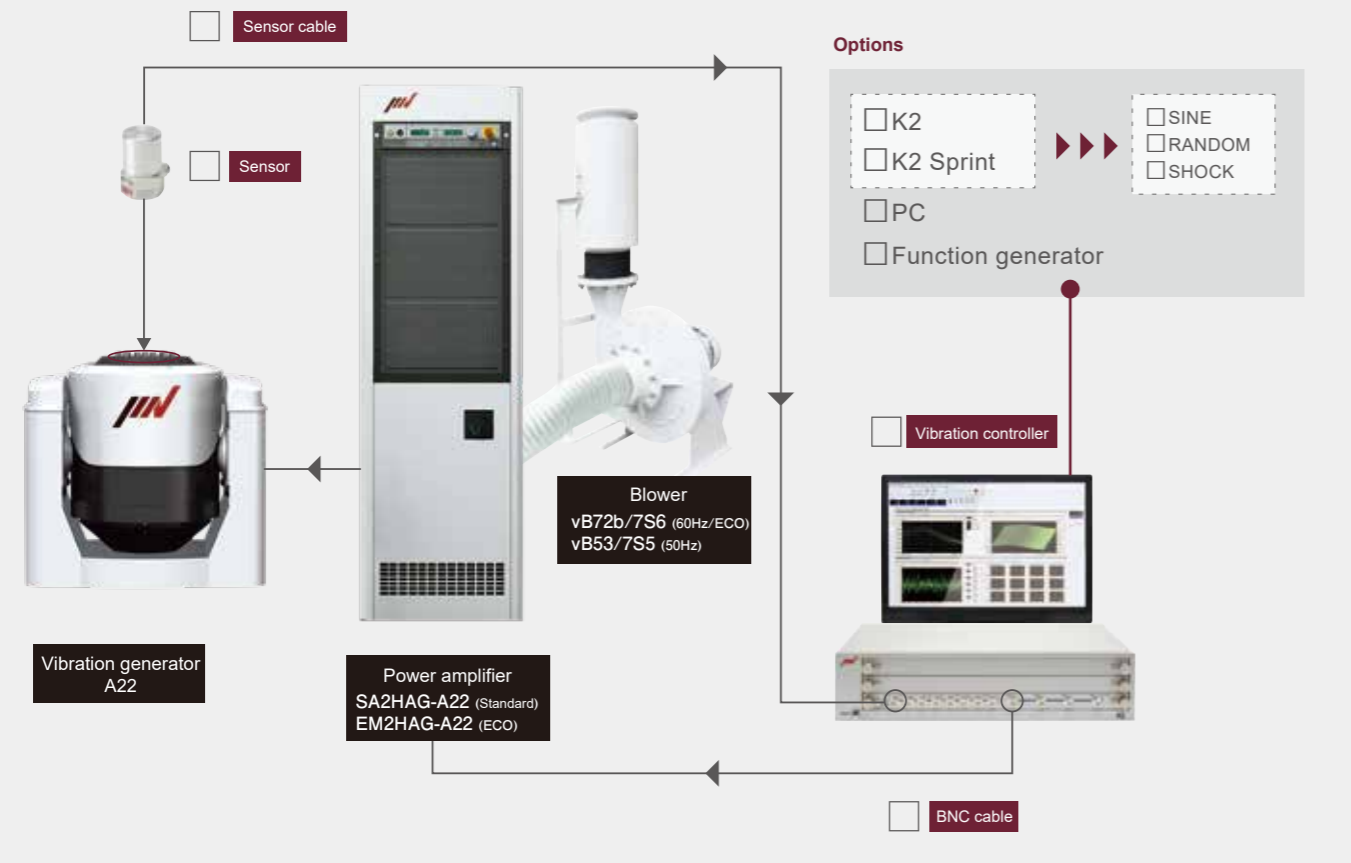

Head expander compatible with A22

Use a head expander for test samples that are too large to put on the table. The test sample mass must fall within the load limit of the shaker (300 kg) minus the head expander mass. When using the head expander, the upper limit frequency is smaller than when using the test system alone.

Model	Dimensions (mm)	Mass (kg)	Maximum frequency (Hz)	Material
<input type="checkbox"/> TBV-315-A22-A	315 × 315 × t 30	8.5	1000	Aluminum alloy
<input type="checkbox"/> TBV-315-A22-M	315 × 315 × t 30	5.8	1000	Magnesium alloy
<input type="checkbox"/> TBV-400-A22-A	400 × 400 × t 30	13	600	Aluminum alloy
<input type="checkbox"/> TBV-400-A22-M	400 × 400 × t 30	9	600	Magnesium alloy
<input type="checkbox"/> TBV-500-A22-A	500 × 500 × t 40	15	500	Aluminum alloy
<input type="checkbox"/> TBV-500-A22-M	500 × 500 × t 40	10.4	500	Magnesium alloy
<input type="checkbox"/> TBV-630-A22-A	630 × 630 × t 45	19	360	Aluminum alloy
<input type="checkbox"/> TBV-630-A22-M	630 × 630 × t 45	12.5	360	Magnesium alloy
<input type="checkbox"/> TBV-800-A22-A	800 × 800 × t 70	45	350	Aluminum alloy
<input type="checkbox"/> TBV-800-A22-M	800 × 800 × t 70	30	350	Magnesium alloy
<input type="checkbox"/> TBV-1000-A22-A	1000 × 1000 × t 110	110	350	Aluminum alloy
<input type="checkbox"/> TBV-1000-A22-M	1000 × 1000 × t 110	78	350	Magnesium alloy



Slip table compatible with A22

Use a slip table for test samples that are too large to put on the table. The test sample mass must fall within the load limit of the shaker (300 kg) minus the head expander mass. When using the head expander, the upper limit frequency is smaller than when using the test system alone.

MB: Mechanical Bearing

The mechanical bearing uses a linear motion guide which has a component with a linear rolling motion. It contributes substantially to the high performance of tables with high rigidity, high load, and long stroke motion. Another strong feature of the mechanical bearing is its easy operability, since it is lightweight and has no need for a hydraulic unit.

Model	Dimensions (mm)	Mass (kg)	Maximum frequency (Hz)	Material
<input type="checkbox"/> TBH-550-A22-A-MB	550 × 550 × t 40	58	2000	Aluminum alloy
<input type="checkbox"/> TBH-750-A22-A-MB	750 × 750 × t 40	95	2000	Aluminum alloy
<input type="checkbox"/> TBH-950-A22-A-MB	950 × 950 × t 40	140	1250	Aluminum alloy
<input type="checkbox"/> TBH-1150-A22-A-MB	1150 × 1150 × t 40	200	800	Aluminum alloy

*The weight applies to a plate made of aluminum. Please contact us for a plate made of magnesium.



Cubic fixtures compatible with A22

The specimen can be fastened to the top or side face of the cubic fixture where testing in each axis is required. Two types of cubic fixture are available. Type A has mounting holes on each face and Type B has specimen mounting plates which attach to the cubic frame.

Model	Dimensions (mm)	Mass (kg)	Maximum frequency (Hz)	Material
<input type="checkbox"/> TCJ-A150-A22-A	150 × 150 × 150	5.5	2000	Aluminum alloy
<input type="checkbox"/> TCJ-A150-A22-M	150 × 150 × 150	4.0	2000	Magnesium alloy
<input type="checkbox"/> TCJ-A160-A22-A	160 × 160 × 160	6.5	2000	Aluminum alloy
<input type="checkbox"/> TCJ-A160-A22-M	160 × 160 × 160	4.6	2000	Magnesium alloy
<input type="checkbox"/> TCJ-A200-A22-A	200 × 200 × 200	8	1000	Aluminum alloy
<input type="checkbox"/> TCJ-A200-A22-M	200 × 200 × 200	5.6	1000	Magnesium alloy
<input type="checkbox"/> TCJ-A250-A22-A	250 × 250 × 250	13.5	650	Aluminum alloy
<input type="checkbox"/> TCJ-A250-A22-M	250 × 250 × 250	9.5	650	Magnesium alloy
<input type="checkbox"/> TCJ-B150-A22-A	150 × 150 × 150	3.5	2000	Aluminum alloy
<input type="checkbox"/> TCJ-B150-A22-M	150 × 150 × 150	2.5	2000	Magnesium alloy
<input type="checkbox"/> TCJ-B160-A22-A	160 × 160 × 160	4.0	2000	Aluminum alloy
<input type="checkbox"/> TCJ-B160-A22-M	160 × 160 × 160	2.8	2000	Magnesium alloy
<input type="checkbox"/> TCJ-B200-A22-A	200 × 200 × 200	10	2000	Aluminum alloy
<input type="checkbox"/> TCJ-B200-A22-M	200 × 200 × 200	7	2000	Magnesium alloy
<input type="checkbox"/> TCJ-B250-A22-A	250 × 250 × 250	20	1000	Aluminum alloy
<input type="checkbox"/> TCJ-B250-A22-M	250 × 250 × 250	14	1000	Magnesium alloy

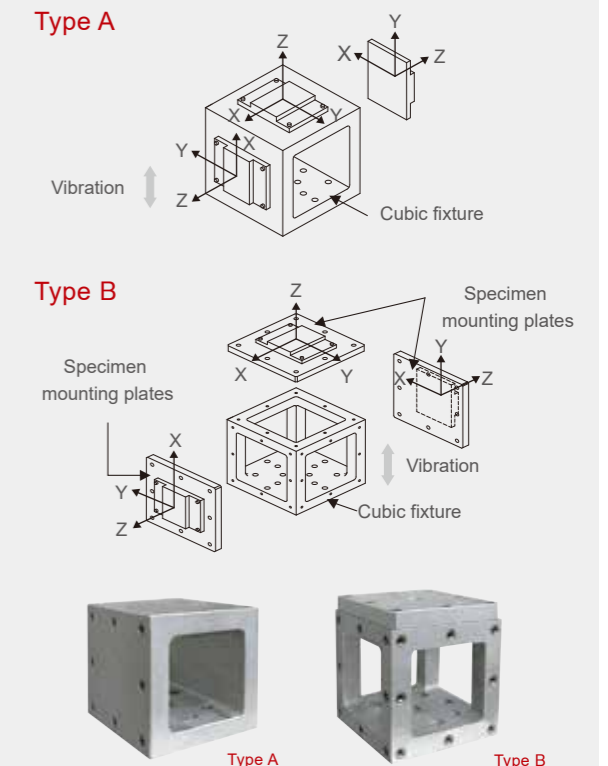

Type A Type B

A30/SA3HAG (Standard) A30/EM3HAG (ECO)

A wider range of test requirements and higher test specifications.



System Model		A30/SA3HAG	A30/EM3HAG	Model	A30
Frequency Range (Hz)		0 – 2600	0 – 2600	Armature Mass (kg)	33
Rated Force	Sine (kN)	30	30	Armature Diameter (φmm)	290
	Random (kN rms)*1	30	30	Allowable Eccentric Moment (N · m)	850
	Shock (kN)	60	60	Dimensions (mm) W × H × D	1100 × 1048 × 840
	High Velocity Shock (kN)	—	50	Shaker Body Diameter (φmm)	725
Maximum Acc.	Sine (m/s ²)	900	900	Mass (kg)	2000
	Random (m/s ² rms)	630	630	Model	SA3HAG-A30 EM3HAG-A30
	Shock (m/s ² peak)	1818	1818	Maximum Output (kVA)	31
	High Velocity Shock (m/s ² peak)	—	1515	Dimensions (mm) W × H × D	580 × 1950 × 850
Maximum Vel.	Sine (m/s)	2.0	2.0	Mass (kg)	520 590
	Shock (m/s peak)	2.5	2.5	Controller	Vibration Controller
Maximum Disp.	Sine (mmp-p)	76.2	76.2	Cooling Method	Air cooling
	High Velocity Shock (mmp-p)	—	76.2	Blower	Dimensions (mm) W × H × D**
Maximum Travel (mmp-p)		82	82	Mass (kg)	210
Maximum Load (kg)		400	400	Wattage (kw)	5.5
Power Requirements (kVA)*2		36	36	Duct Hose Diameter (φ)	200
Breaker Capacity (A)*3		125	125		

*1 Random force ratings are specified in accordance with ISO5344 conditions. Please contact IMV or your local distributor with specific test requirements.
 *2 Power supply: 3-phase 200/220/380/400/415 V, 50/60 Hz. A transformer is required for other supply voltages.
 *3 Breaker capacity for AC 200 V.
 *4 The specification above applies to 60 Hz. Dimensions change for 50 Hz.
 *The specifications show the maximum system performance. For long-duration tests, system must be de-rated up to 70%. Continuous use at maximum levels may cause failure. Please contact IMV if your system operates at more than 70%.
 *For random vibration tests, please set the test definition of the peak value of acceleration waveform to operate at less than the maximum acceleration of shock.
 *Frequency range values vary according to the sensor and vibration controller.
 *Armature mass and acceleration may change when a chamber is added.
 **Mass and dimensions may change for CE-marked systems.

Head expander compatible with A30

Use a head expander for test samples that are too large to put on the table. The test sample mass must fall within the load limit of the shaker (400 kg) minus the head expander mass. When using the head expander, the upper limit frequency is smaller than when using the test system alone.

Model	Dimensions (mm)	Mass (kg)	Maximum frequency (Hz)	Material
<input type="checkbox"/> TBV-315-A30-A	315 × 315 × t 30	8.5	1000	Aluminum alloy
<input type="checkbox"/> TBV-315-A30-M	315 × 315 × t 30	5.8	1000	Magnesium alloy
<input type="checkbox"/> TBV-400-A30-A	400 × 400 × t 30	13	600	Aluminum alloy
<input type="checkbox"/> TBV-400-A30-M	400 × 400 × t 30	9	600	Magnesium alloy
<input type="checkbox"/> TBV-500-A30-A	500 × 500 × t 40	15	500	Aluminum alloy
<input type="checkbox"/> TBV-500-A30-M	500 × 500 × t 40	10.4	500	Magnesium alloy
<input type="checkbox"/> TBV-630-A30-A	630 × 630 × t 45	19	360	Aluminum alloy
<input type="checkbox"/> TBV-630-A30-M	630 × 630 × t 45	12.5	360	Magnesium alloy
<input type="checkbox"/> TBV-800-A30-A	800 × 800 × t 70	45	350	Aluminum alloy
<input type="checkbox"/> TBV-800-A30-M	800 × 800 × t 70	30	350	Magnesium alloy
<input type="checkbox"/> TBV-1000-A30-A	1000 × 1000 × t 110	110	350	Aluminum alloy
<input type="checkbox"/> TBV-1000-A30-M	1000 × 1000 × t 110	78	350	Magnesium alloy



Slip table compatible with A30

Use a slip table for test samples that are too large to put on the table. The test sample mass must fall within the load limit of the shaker (400 kg) minus the head expander mass. When using the head expander, the upper limit frequency is smaller than when using the test system alone.

MB: Mechanical Bearing

The mechanical bearing uses a linear motion guide which has a component with a linear rolling motion. It contributes substantially to the high performance of tables with high rigidity, high load, and long stroke motion. Another strong feature of the mechanical bearing is its easy operability, since it is lightweight and has no need for a hydraulic unit.

Model	Dimensions (mm)	Mass (kg)	Maximum frequency (Hz)	Material
<input type="checkbox"/> TBH-550-A30-A-MB	550 × 550 × t 40	60	2000	Aluminum alloy
<input type="checkbox"/> TBH-750-A30-A-MB	750 × 750 × t 40	100	2000	Aluminum alloy
<input type="checkbox"/> TBH-950-A30-A-MB	950 × 950 × t 40	145	1250	Aluminum alloy
<input type="checkbox"/> TBH-1150-A30-A-MB	1150 × 1150 × t 40	208	800	Aluminum alloy

*The weight applies to a plate made of aluminum. Please contact us for a plate made of magnesium.



System composition

■ Standard equipment ■ Optional items

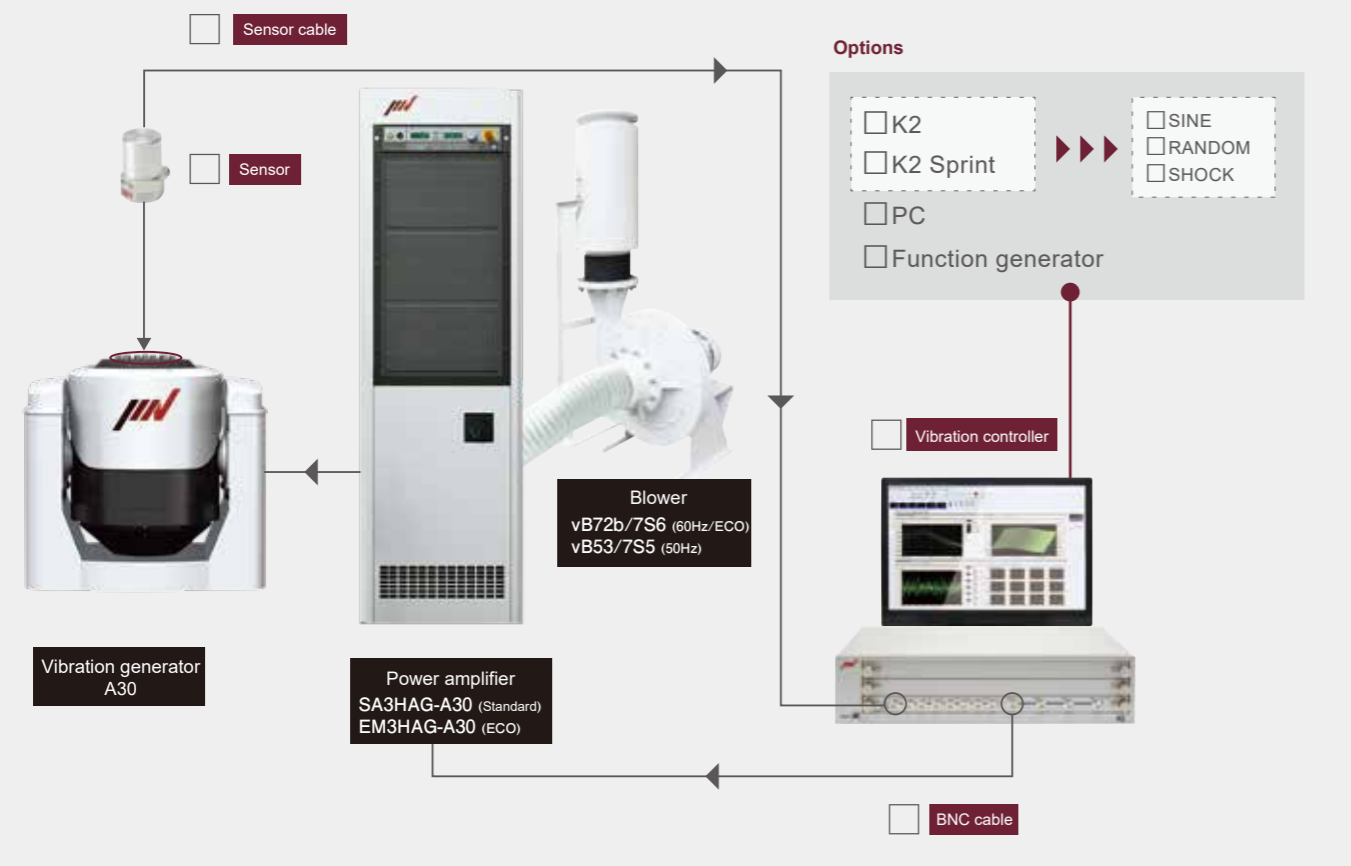

Cubic fixtures compatible with A30

The specimen can be fastened to the top or the side face of the cubic fixture where testing in each axis is required. Two types of cubic fixture are available. Type A has mounting holes on each face and Type B has specimen mounting plates which attach to the cubic frame.

Model	Dimensions (mm)	Mass (kg)	Maximum frequency (Hz)	Material
<input type="checkbox"/> TCJ-A150-A30-A	150 × 150 × 150	5.5	2000	Aluminum alloy
<input type="checkbox"/> TCJ-A150-A30-M	150 × 150 × 150	4.0	2000	Magnesium alloy
<input type="checkbox"/> TCJ-A160-A30-A	160 × 160 × 160	6.5	2000	Aluminum alloy
<input type="checkbox"/> TCJ-A160-A30-M	160 × 160 × 160	4.6	2000	Magnesium alloy
<input type="checkbox"/> TCJ-A200-A30-A	200 × 200 × 200	8	1000	Aluminum alloy
<input type="checkbox"/> TCJ-A200-A30-M	200 × 200 × 200	5.6	1000	Magnesium alloy
<input type="checkbox"/> TCJ-A250-A30-A	250 × 250 × 250	13.5	650	Aluminum alloy
<input type="checkbox"/> TCJ-A250-A30-M	250 × 250 × 250	9.5	650	Magnesium alloy
<input type="checkbox"/> TCJ-A300-A30-A	300 × 300 × 300	20	400	Aluminum alloy
<input type="checkbox"/> TCJ-A300-A30-M	300 × 300 × 300	14	400	Magnesium alloy
<input type="checkbox"/> TCJ-B150-A30-A	150 × 150 × 150	3.5	2000	Aluminum alloy
<input type="checkbox"/> TCJ-B150-A30-M	150 × 150 × 150	2.5	2000	Magnesium alloy
<input type="checkbox"/> TCJ-B160-A30-A	160 × 160 × 160	4.0	2000	Aluminum alloy
<input type="checkbox"/> TCJ-B160-A30-M	160 × 160 × 160	2.8	2000	Magnesium alloy
<input type="checkbox"/> TCJ-B200-A30-A	200 × 200 × 200	10	2000	Aluminum alloy
<input type="checkbox"/> TCJ-B200-A30-M	200 × 200 × 200	7	2000	Magnesium alloy
<input type="checkbox"/> TCJ-B250-A30-A	250 × 250 × 250	20	1000	Aluminum alloy
<input type="checkbox"/> TCJ-B250-A30-M	250 × 250 × 250	14	1000	Magnesium alloy
<input type="checkbox"/> TCJ-B300-A30-A	300 × 300 × 300	20	600	Aluminum alloy
<input type="checkbox"/> TCJ-B300-A30-M	300 × 300 × 300	14	600	Magnesium alloy

Type A

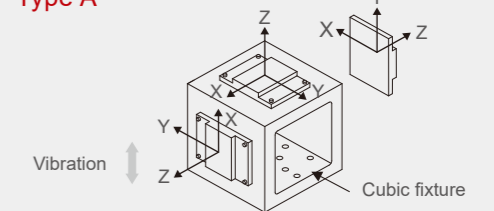

Type B

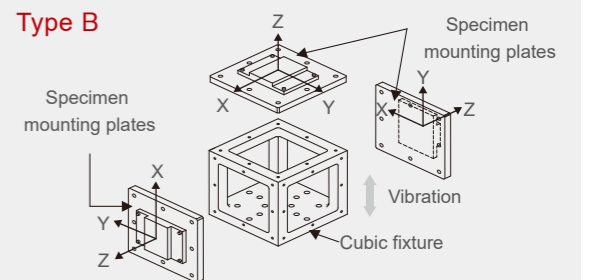

A45/SA4HAG (Standard) A45/EM4HAG (ECO)

A wider range of test requirements and higher test specifications.



System Model		A45/SA4HAG	A45/EM4HAG	Model	A45
Frequency Range (Hz)		0 – 2600	0 – 2600	Armature Mass (kg)	50
Rated Force	Sine (kN)	45	45	Armature Diameter (φmm)	436
	Random (kN rms)*1	45	45	Allowable Eccentric Moment (N · m)	1550
	Shock (kN)	90	90	Dimensions (mm) W × H × D	1232 × 1215 × 1040
	High Velocity Shock (kN)	—	80	Shaker Body Diameter (φmm)	825
Maximum Acc.	Sine (m/s ²)	900	900	Mass (kg)	3000
	Random (m/s ² rms)	630	630	Model	SA4HAG-A45 EM4HAG-A45
	Shock (m/s ² peak)	1800	1800	Maximum Output (kVA)	44
	High Velocity Shock (m/s ² peak)	—	1600	Dimensions (mm) W × H × D	580 × 1950 × 850 1160 × 1950 × 850
Maximum Vel.	Sine (m/s)	2.0	2.0	Mass (kg)	900 1000
	Shock (m/s peak)	2.5	2.5	Controller	Vibration Controller
Maximum Disp.	Sine (mmp-p)	76.2	76.2	Cooling Method	Air cooling
	High Velocity Shock (mmp-p)	—	76.2	Blower	Dimensions (mm) W × H × D**
Maximum Travel (mmp-p)		82	82	Mass (kg)	250 280
Maximum Load (kg)		600	600	Wattage (kw)	11
Power Requirements (kVA)**		57	57	Duct Hose Diameter (φ)	250
Breaker Capacity (A)**		200	200		

*1 Random force ratings are specified in accordance with ISO5344 conditions. Please contact IMV or your local distributor with specific test requirements.
 *2 Power supply: 3-phase 200/220/380/400/415 V, 50/60 Hz. A transformer is required for other supply voltages.
 *3 Breaker capacity for AC 200 V.
 *4 The specification above applies to 60 Hz. Dimensions change for 50 Hz.
 *The specifications show the maximum system performance. For long-duration tests, system must be de-rated up to 70%. Continuous use at maximum levels may cause failure. Please contact IMV if your system operates at more than 70%.
 *For random vibration tests, please set the test definition of the peak value of acceleration waveform to operate at less than the maximum acceleration of shock.
 *Frequency range values vary according to the sensor and vibration controller.
 *Armature mass and acceleration may change when a chamber is added.
 **Mass and dimensions may change for CE-marked systems.

System composition

■ Standard equipment ■ Optional items

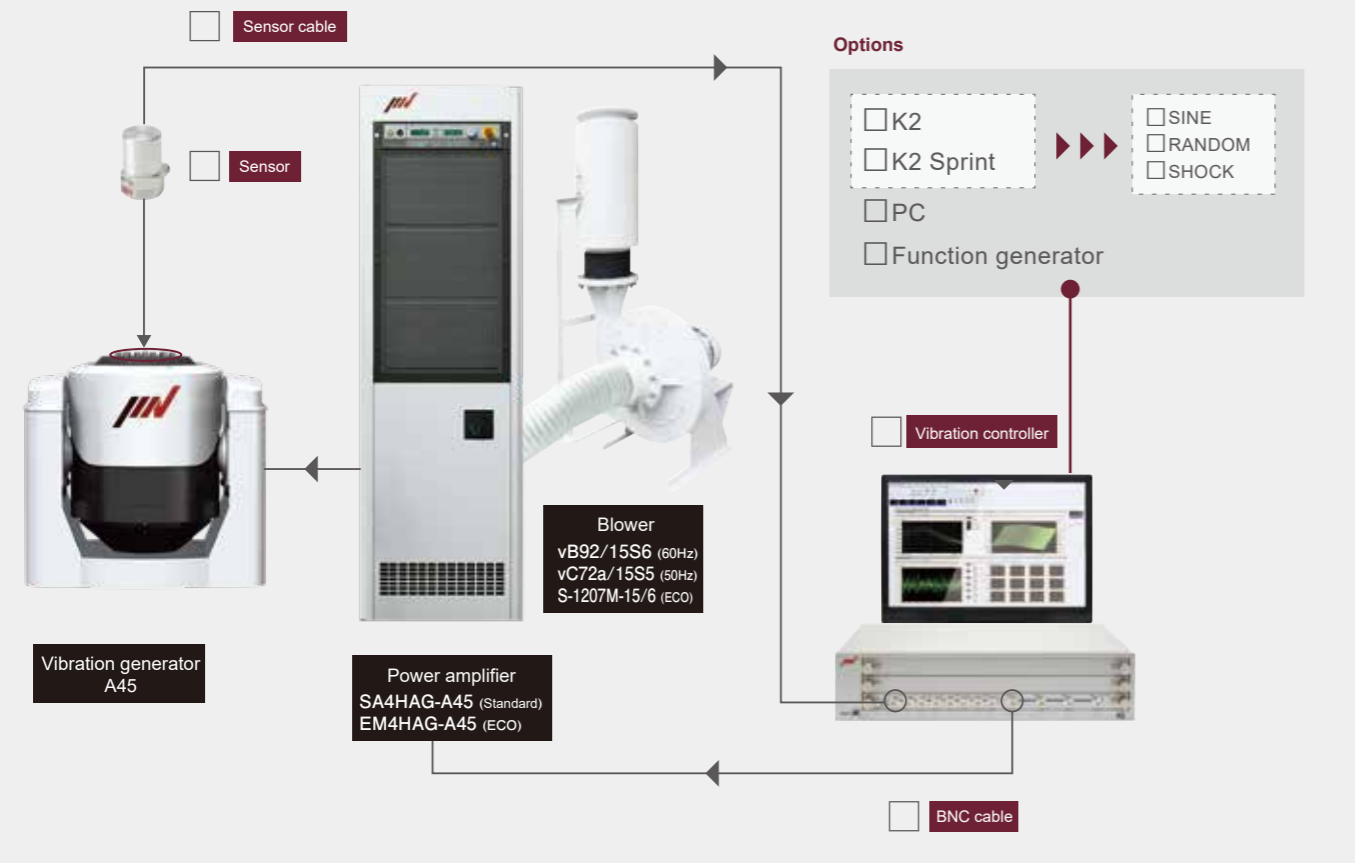

Head expander compatible with A45

Use a head expander for test samples that are too large to put on the table. The test sample mass must fall within the load limit of the shaker (600 kg) minus the head expander mass. When using the head expander, the upper limit frequency is smaller than when using the test system alone.

Model	Dimensions (mm)	Mass (kg)	Maximum frequency (Hz)	Material
<input type="checkbox"/> TBV-315-A45-A	315 × 315 × t 30	8.5	1000	Aluminum alloy
<input type="checkbox"/> TBV-315-A45-M	315 × 315 × t 30	5.8	1000	Magnesium alloy
<input type="checkbox"/> TBV-400-A45-A	400 × 400 × t 30	13	600	Aluminum alloy
<input type="checkbox"/> TBV-400-A45-M	400 × 400 × t 30	9	600	Magnesium alloy
<input type="checkbox"/> TBV-500-A45-A	500 × 500 × t 40	15	500	Aluminum alloy
<input type="checkbox"/> TBV-500-A45-M	500 × 500 × t 40	10.4	500	Magnesium alloy
<input type="checkbox"/> TBV-630-A45-A	630 × 630 × t 45	19	360	Aluminum alloy
<input type="checkbox"/> TBV-630-A45-M	630 × 630 × t 45	12.5	360	Magnesium alloy
<input type="checkbox"/> TBV-800-A45-A	800 × 800 × t 70	45	350	Aluminum alloy
<input type="checkbox"/> TBV-800-A45-M	800 × 800 × t 70	30	350	Magnesium alloy
<input type="checkbox"/> TBV-1000-A45-A	1000 × 1000 × t 110	110	350	Aluminum alloy
<input type="checkbox"/> TBV-1000-A45-M	1000 × 1000 × t 110	78	350	Magnesium alloy



Slip table compatible with A45

Use a slip table for test samples that are too large to put on the table. The test sample mass must fall within the load limit of the shaker (600 kg) minus the head expander mass. When using the head expander, the upper limit frequency is smaller than when using the test system alone.

MB: Mechanical Bearing

The mechanical bearing uses a linear motion guide which has a component with a linear rolling motion. It contributes substantially to the high performance of tables with high rigidity, high load, and long stroke motion. Another strong feature of the mechanical bearing is its easy operability, since it is lightweight and has no need for a hydraulic unit.

Model	Dimensions (mm)	Mass (kg)	Maximum frequency (Hz)	Material
<input type="checkbox"/> TBH-550-A45-A-MB	550 × 550 × t 40	68	2000	Aluminum alloy
<input type="checkbox"/> TBH-750-A45-A-MB	750 × 750 × t 40	108	2000	Aluminum alloy
<input type="checkbox"/> TBH-950-A45-A-MB	950 × 950 × t 40	153	1250	Aluminum alloy
<input type="checkbox"/> TBH-1150-A45-A-MB	1150 × 1150 × t 40	213	800	Aluminum alloy

*The weight applies to a plate made of aluminum. Please contact us for a plate made of magnesium.



Cubic fixtures compatible with A45

The specimen can be fastened to the top or the side face of the cubic fixture where testing in each axis is required. Two types of cubic fixture are available. Type A has mounting holes on each face and Type B has specimen mounting plates which attach to the cubic frame.

Model	Dimensions (mm)	Mass (kg)	Maximum frequency (Hz)	Material
<input type="checkbox"/> TCJ-A150-A45-A	150 × 150 × 150	5.5	2000	Aluminum alloy
<input type="checkbox"/> TCJ-A150-A45-M	150 × 150 × 150	4.0	2000	Magnesium alloy
<input type="checkbox"/> TCJ-A160-A45-A	160 × 160 × 160	6.5	2000	Aluminum alloy
<input type="checkbox"/> TCJ-A160-A45-M	160 × 160 × 160	4.6	2000	Magnesium alloy
<input type="checkbox"/> TCJ-A200-A45-A	200 × 200 × 200	8	1000	Aluminum alloy
<input type="checkbox"/> TCJ-A200-A45-M	200 × 200 × 200	5.6	1000	Magnesium alloy
<input type="checkbox"/> TCJ-A250-A45-A	250 × 250 × 250	13.5	650	Aluminum alloy
<input type="checkbox"/> TCJ-A250-A45-M	250 × 250 × 250	9.5	650	Magnesium alloy
<input type="checkbox"/> TCJ-A300-A45-A	300 × 300 × 300	20	400	Aluminum alloy
<input type="checkbox"/> TCJ-A300-A45-M	300 × 300 × 300	14	400	Magnesium alloy
<input type="checkbox"/> TCJ-B150-A45-A	150 × 150 × 150	3.5	2000	Aluminum alloy
<input type="checkbox"/> TCJ-B150-A45-M	150 × 150 × 150	2.5	2000	Magnesium alloy
<input type="checkbox"/> TCJ-B160-A45-A	160 × 160 × 160	4.0	2000	Aluminum alloy
<input type="checkbox"/> TCJ-B160-A45-M	160 × 160 × 160	2.8	2000	Magnesium alloy
<input type="checkbox"/> TCJ-B200-A45-A	200 × 200 × 200	10	2000	Aluminum alloy
<input type="checkbox"/> TCJ-B200-A45-M	200 × 200 × 200	7	2000	Magnesium alloy
<input type="checkbox"/> TCJ-B250-A45-A	250 × 250 × 250	20	1000	Aluminum alloy
<input type="checkbox"/> TCJ-B250-A45-M	250 × 250 × 250	14	1000	Magnesium alloy
<input type="checkbox"/> TCJ-B300-A45-A	300 × 300 × 300	20	600	Aluminum alloy
<input type="checkbox"/> TCJ-B300-A45-M	300 × 300 × 300	14	600	Magnesium alloy

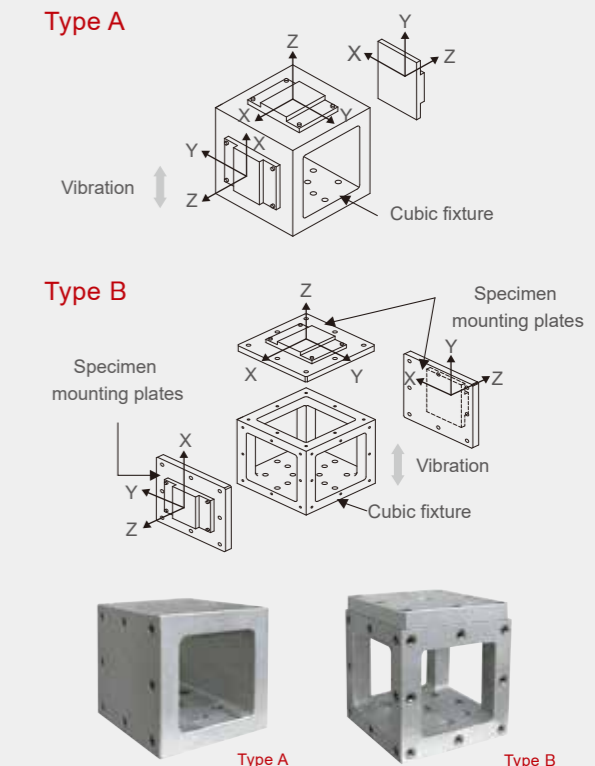

A65/SA5HAG (Standard) A65/EM5HAG (ECO)

A wider range of test requirements and higher test specifications.



System Model		A65/SA5HAG**	A65/EM5HAG**	Model	A65
Frequency Range (Hz)		0 - 2600**	0 - 2600**	Armature Mass (kg)	72
Rated Force	Sine (kN)	65	65	Armature Diameter (φmm)	446
	Random (kN rms)*1	65	65	Allowable Eccentric Moment (N · m)	1550
	Shock (kN)	130	130	Dimensions (mm) W × H × D	1310 × 1253 × 1040
	High Velocity Shock (kN)	—	120	Shaker Body Diameter (φmm)	925
Maximum Acc.	Sine (m/s ²)	900	900	Mass (kg)	4200
	Random (m/s ² rms)	630	630	Model	SA5HAG-A65 EM5HAG-A65
	Shock (m/s ² peak)	1806	1806	Maximum Output (kVA)	68
	High Velocity Shock (m/s ² peak)	—	1666	Dimensions (mm) W × H × D	580 × 1950 × 850 1160 × 1950 × 850
Maximum Vel.	Sine (m/s)	2.0	2.0	Mass (kg)	1000 1150
	Shock (m/s peak)	2.5	2.5	Controller	Vibration Controller See Vibration Controller K2
Maximum Disp.	Sine (mmp-p)	76.2	76.2	Cooling Method	Air cooling
	High Velocity Shock (mmp-p)	—	76.2	Blower	Dimensions (mm) W × H × D*5 1214 × 2006 × 1124 1126 × 2380 × 899
Maximum Travel (mmp-p)		82	82	Mass (kg)	420 228
Maximum Load (kg)		1000	1000	Wattage (kw)	18.5
Power Requirements (kVA)*2		83	83	Duct Hose Diameter (φ)	250
Breaker Capacity (A)*3		300	300		

*1 Random force ratings are specified in accordance with ISO5344 conditions. Please contact IMV or your local distributor with specific test requirements.
 *2 Power supply: 3-phase 200/220/380/400/415 V, 50/60 Hz. A transformer is required for other supply voltages.
 *3 Breaker capacity for AC 200 V.
 *4 Above 2000 Hz, the force rolls-off at a rate of -12 dB/oct.
 *5 The specification above applies to 60 Hz. Dimensions change for 50 Hz.
 *6 Export license is required for exporting the shaker system of over 50 kN sine force.
 *The specifications show the maximum system performance. For long-duration tests, system must be de-rated up to 70%.
 *Continuous use at maximum levels may cause failure. Please contact IMV if your system operates at more than 70%.
 *For random vibration tests, please set the test definition of the peak value of acceleration waveform to operate at less than the maximum acceleration of shock.
 *Frequency range values vary according to the sensor and vibration controller.
 *Armature mass and acceleration may change when a chamber is added.
 *Mass and dimensions may change for CE-marked systems.

System composition

■ Standard equipment ■ Optional items

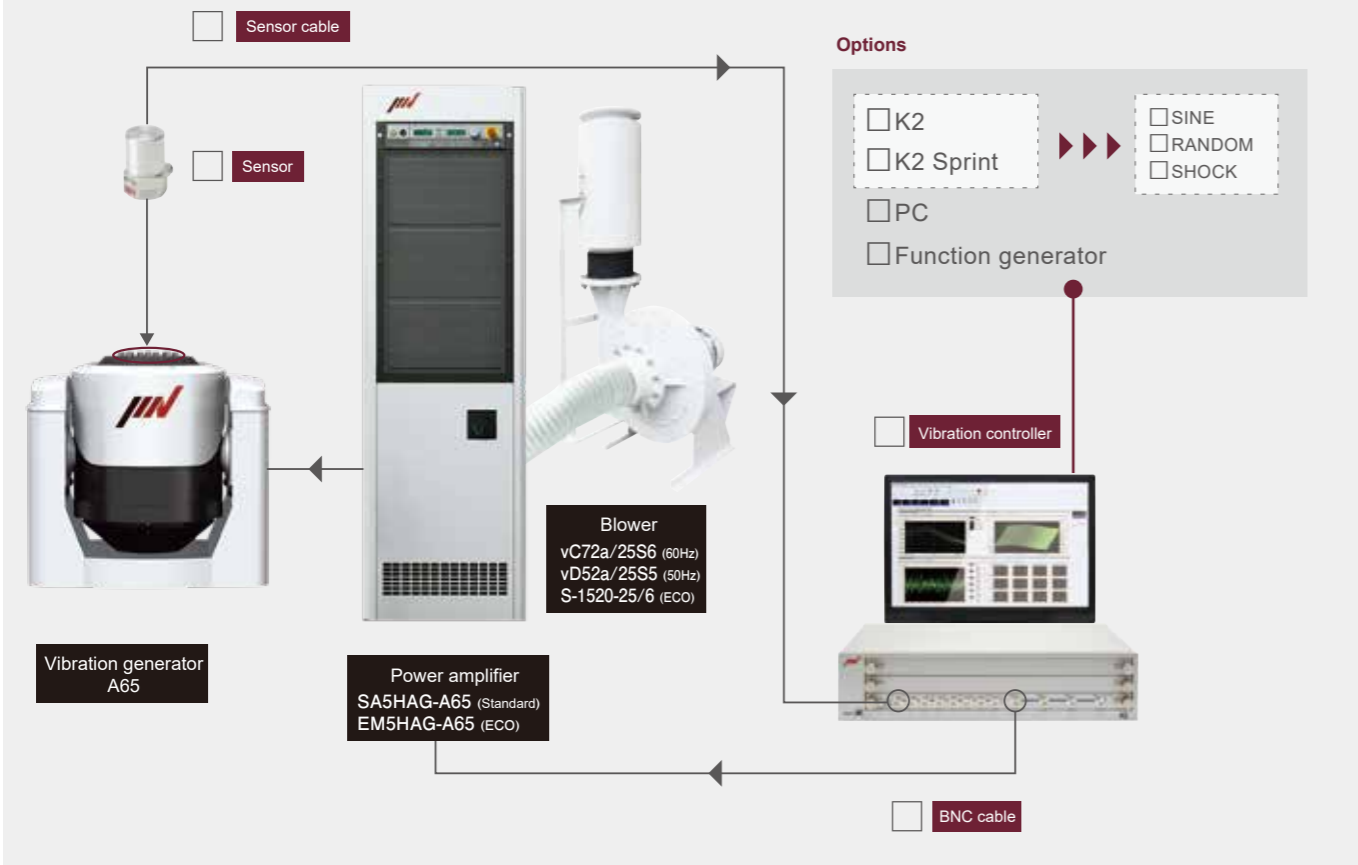

Head expander compatible with A65

Use a head expander for test samples that are too large to put on the table. The test sample mass must fall within the load limit of the shaker (1,000 kg) minus the head expander mass. When using the head expander, the upper limit frequency is smaller than when using the test system alone.

Model	Dimensions (mm)	Mass (kg)	Maximum frequency (Hz)	Material
<input type="checkbox"/> TBV-315-A65-A	315 × 315 × t 30	8.5	1000	Aluminum alloy
<input type="checkbox"/> TBV-315-A65-M	315 × 315 × t 30	5.8	1000	Magnesium alloy
<input type="checkbox"/> TBV-400-A65-A	400 × 400 × t 30	13	600	Aluminum alloy
<input type="checkbox"/> TBV-400-A65-M	400 × 400 × t 30	9	600	Magnesium alloy
<input type="checkbox"/> TBV-500-A65-A	500 × 500 × t 40	15	500	Aluminum alloy
<input type="checkbox"/> TBV-500-A65-M	500 × 500 × t 40	10.4	500	Magnesium alloy
<input type="checkbox"/> TBV-630-A65-A	630 × 630 × t 45	19	360	Aluminum alloy
<input type="checkbox"/> TBV-630-A65-M	630 × 630 × t 45	12.5	360	Magnesium alloy
<input type="checkbox"/> TBV-800-A65-A	800 × 800 × t 70	45	350	Aluminum alloy
<input type="checkbox"/> TBV-800-A65-M	800 × 800 × t 70	30	350	Magnesium alloy
<input type="checkbox"/> TBV-1000-A65-A	1000 × 1000 × t 110	110	350	Aluminum alloy
<input type="checkbox"/> TBV-1000-A65-M	1000 × 1000 × t 110	78	350	Magnesium alloy



Slip table compatible with A65

Use a slip table for test samples that are too large to put on the table. The test sample mass must fall within the load limit of the shaker (1,000 kg) minus the head expander mass. When using the head expander, the upper limit frequency is smaller than when using the test system alone.

MB: Mechanical Bearing

The mechanical bearing uses a linear motion guide which has a component with a linear rolling motion. It contributes substantially to the high performance of tables with high rigidity, high load, and long stroke motion. Another strong feature of the mechanical bearing is its easy operability, since it is lightweight and has no need for a hydraulic unit.

Model	Dimensions (mm)	Mass (kg)	Maximum frequency (Hz)	Material
<input type="checkbox"/> TBH-550-A65-A-MB	550 × 550 × t 40	68	2000	Aluminum alloy
<input type="checkbox"/> TBH-750-A65-A-MB	750 × 750 × t 40	108	2000	Aluminum alloy
<input type="checkbox"/> TBH-950-A65-A-MB	950 × 950 × t 40	153	1250	Aluminum alloy
<input type="checkbox"/> TBH-1150-A65-A-MB	1150 × 1150 × t 40	213	800	Aluminum alloy

*The weight applies to a plate made of aluminum. Please contact us for a plate made of magnesium.



Cubic fixtures compatible with A65

The specimen can be fastened to the top or the side face of the cubic fixture where testing in each axis is required. Two types of cubic fixture are available. Type A has mounting holes on each face and Type B has specimen mounting plates which attach to the cubic frame.

Model	Dimensions (mm)	Mass (kg)	Maximum frequency (Hz)	Material
<input type="checkbox"/> TCJ-A150-A65-A	150 × 150 × 150	5.5	2000	Aluminum alloy
<input type="checkbox"/> TCJ-A150-A65-M	150 × 150 × 150	4.0	2000	Magnesium alloy
<input type="checkbox"/> TCJ-A160-A65-A	160 × 160 × 160	6.5	2000	Aluminum alloy
<input type="checkbox"/> TCJ-A160-A65-M	160 × 160 × 160	4.6	2000	Magnesium alloy
<input type="checkbox"/> TCJ-A200-A65-A	200 × 200 × 200	8	1000	Aluminum alloy
<input type="checkbox"/> TCJ-A200-A65-M	200 × 200 × 200	5.6	1000	Magnesium alloy
<input type="checkbox"/> TCJ-A250-A65-A	250 × 250 × 250	13.5	650	Aluminum alloy
<input type="checkbox"/> TCJ-A250-A65-M	250 × 250 × 250	9.5	650	Magnesium alloy
<input type="checkbox"/> TCJ-A300-A65-A	300 × 300 × 300	20	400	Aluminum alloy
<input type="checkbox"/> TCJ-A300-A65-M	300 × 300 × 300	14	400	Magnesium alloy
<input type="checkbox"/> TCJ-B150-A65-A	150 × 150 × 150	3.5	2000	Aluminum alloy
<input type="checkbox"/> TCJ-B150-A65-M	150 × 150 × 150	2.5	2000	Magnesium alloy
<input type="checkbox"/> TCJ-B160-A65-A	160 × 160 × 160	4.0	2000	Aluminum alloy
<input type="checkbox"/> TCJ-B160-A65-M	160 × 160 × 160	2.8	2000	Magnesium alloy
<input type="checkbox"/> TCJ-B200-A65-A	200 × 200 × 200	10	2000	Aluminum alloy
<input type="checkbox"/> TCJ-B200-A65-M	200 × 200 × 200	7	2000	Magnesium alloy
<input type="checkbox"/> TCJ-B250-A65-A	250 × 250 × 250	20	1000	Aluminum alloy
<input type="checkbox"/> TCJ-B250-A65-M	250 × 250 × 250	14	1000	Magnesium alloy
<input type="checkbox"/> TCJ-B300-A65-A	300 × 300 × 300	20	600	Aluminum alloy
<input type="checkbox"/> TCJ-B300-A65-M	300 × 300 × 300	14	600	Magnesium alloy

Type A

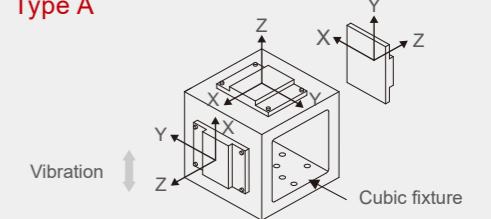

Type B

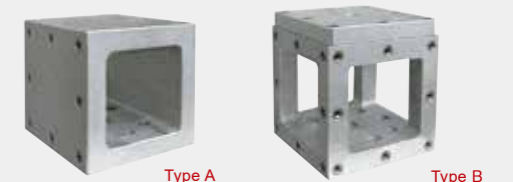
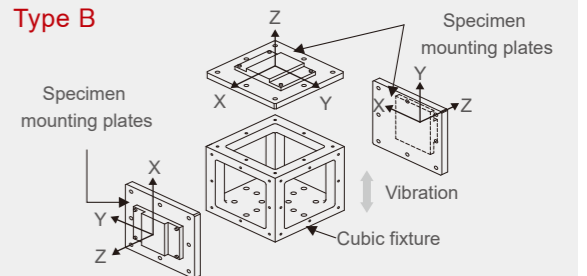

A74/EM6HAG (Standard) A74/EM8HAG (ECO)

A wider range of test requirements and higher test specifications.



System Model		A74/EM6HAG**	A74/EM8HAG**	Model	A74
Frequency Range (Hz)		0 – 2600**	0 – 2600**	Armature Mass (kg)	74
Rated Force	Sine (kN)	74	74	Armature Diameter (φmm)	446
	Random (kN rms)*1	74	74	Allowable Eccentric Moment (N · m)	1550
	Shock (kN)	148	180	Dimensions (mm) W × H × D	1310 × 1253 × 1040
	High Velocity Shock (kN)	120	160	Shaker Body Diameter (φmm)	925
Maximum Acc.	Sine (m/s ²)	1000	1000	Mass (kg)	4800
	Random (m/s ² rms)	630	630	Model	EM6HAG-A74 EM8HAG-A74
	Shock (m/s ² peak)	2000	2000	Maximum Output (kVA)	100
	High Velocity Shock (m/s ² peak)	1621	2000	Dimensions (mm) W × H × D	1160 × 1950 × 850
Maximum Vel.	Sine (m/s)	2.0	2.0	Mass (kg)	1340 1850
	Shock (m/s peak)	2.5	2.5	Controller	Vibration Controller
Maximum Disp.	Sine (mmp-p)	76.2	76.2	Cooling Method	Air cooling
	High Velocity Shock (mmp-p)	76.2	76.2	Blower	Dimensions (mm) W × H × D**
Maximum Travel (mmp-p)		82	82	Mass (kg)	2800 × 927
Maximum Load (kg)		1000	1000	Wattage (kw)	320
Power Requirements (kVA)**		100	100	Duct Hose Diameter (φ)	30
Breaker Capacity (A)**		250	250		250

*1 Random force ratings are specified in accordance with ISO5344 conditions. Please contact IMV or your local distributor with specific test requirements.
 *2 Power supply: 3-phase AC380/400/415 V, 50/60 Hz. A transformer is required for other supply voltages.
 *3 Breaker capacity for AC 200 V.
 *4 Above 2000 Hz, the force rolls-off at a rate of -12 dB/oct.
 *5 The specification above applies to 60 Hz. Dimensions change for 50 Hz.
 *6 Export license is required for exporting the shaker system of over 50 kN sine force.
 **The specifications show the maximum system performance. For long-duration tests, system must be de-rated up to 70%.
 Continuous use at maximum levels may cause failure. Please contact IMV if your system operates at more than 70%.
 *For random vibration tests, please set the test definition of the peak value of acceleration waveform to operate at less than the maximum acceleration of shock.
 *Frequency range values vary according to the sensor and vibration controller.
 *Armature mass and acceleration may change when a chamber is added.
 **Mass and dimensions may change for CE-marked systems.

System composition

■ Standard equipment ■ Optional items

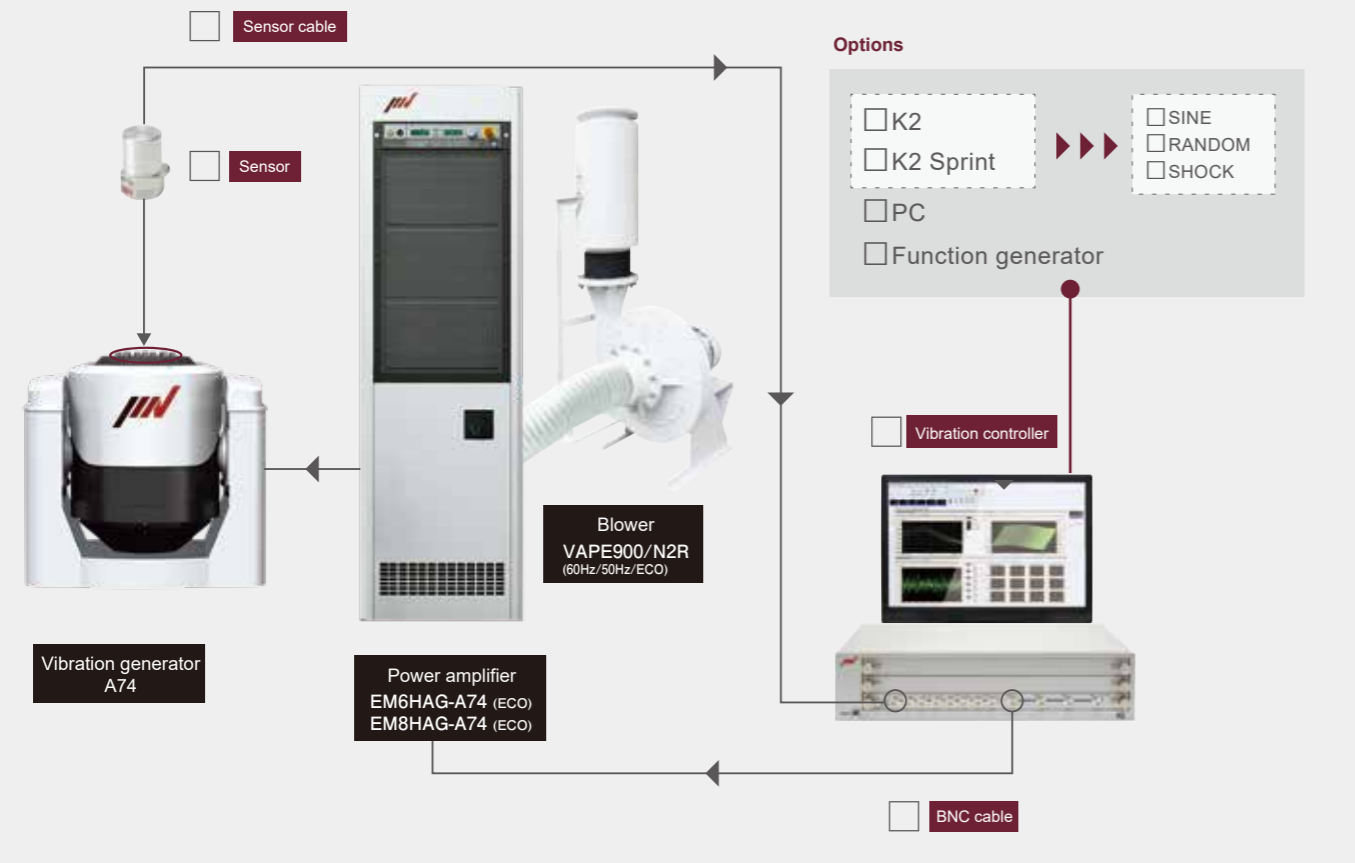

Head expander compatible with A74

Use a head expander for test samples that are too large to put on the table. The test sample mass must fall within the load limit of the shaker (1,000 kg) minus the head expander mass. When using the head expander, the upper limit frequency is smaller than when using the test system alone.

Model	Dimensions (mm)	Mass (kg)	Maximum frequency (Hz)	Material
<input type="checkbox"/> TBV-315-A74-A	315 × 315 × t 30	8.5	1000	Aluminum alloy
<input type="checkbox"/> TBV-315-A74-M	315 × 315 × t 30	5.8	1000	Magnesium alloy
<input type="checkbox"/> TBV-400-A74-A	400 × 400 × t 30	13	600	Aluminum alloy
<input type="checkbox"/> TBV-400-A74-M	400 × 400 × t 30	9	600	Magnesium alloy
<input type="checkbox"/> TBV-500-A74-A	500 × 500 × t 40	15	500	Aluminum alloy
<input type="checkbox"/> TBV-500-A74-M	500 × 500 × t 40	10.4	500	Magnesium alloy
<input type="checkbox"/> TBV-630-A74-A	630 × 630 × t 45	19	360	Aluminum alloy
<input type="checkbox"/> TBV-630-A74-M	630 × 630 × t 45	12.5	360	Magnesium alloy
<input type="checkbox"/> TBV-800-A74-A	800 × 800 × t 70	45	350	Aluminum alloy
<input type="checkbox"/> TBV-800-A74-M	800 × 800 × t 70	30	350	Magnesium alloy
<input type="checkbox"/> TBV-1000-A74-A	1000 × 1000 × t 110	110	350	Aluminum alloy
<input type="checkbox"/> TBV-1000-A74-M	1000 × 1000 × t 110	78	350	Magnesium alloy



Slip table compatible with A74

Use a slip table for test samples that are too large to put on the table. The test sample mass must fall within the load limit of the shaker (1,000 kg) minus the head expander mass. When using the head expander, the upper limit frequency is smaller than when using the test system alone.

MB: Mechanical Bearing

The mechanical bearing uses a linear motion guide which has a component with a linear rolling motion. It contributes substantially to the high performance of the mechanical tables with high rigidity, high load, and long stroke motion. Another strong feature of the mechanical bearing is its easy operability, since it is lightweight and has no need for a hydraulic unit.

Model	Dimensions (mm)	Mass (kg)	Maximum frequency (Hz)	Material
<input type="checkbox"/> TBH-550-A74-A-MB	550 × 550 × t 40	68	2000	Aluminum alloy
<input type="checkbox"/> TBH-750-A74-A-MB	750 × 750 × t 40	108	2000	Aluminum alloy
<input type="checkbox"/> TBH-950-A74-A-MB	950 × 950 × t 40	153	1250	Aluminum alloy
<input type="checkbox"/> TBH-1150-A74-A-MB	1150 × 1150 × t 40	213	800	Aluminum alloy

*The weight applies to a plate made of aluminum. Please contact us for a plate made of magnesium.



Cubic fixtures compatible with A74

The specimen can be fastened to the top or the side face of the cubic fixture where testing in each axis is required. Two types of cubic fixture are available. Type A has mounting holes on each face and Type B has specimen mounting plates which attach to the cubic frame.

Model	Dimensions (mm)	Mass (kg)	Maximum frequency (Hz)	Material
<input type="checkbox"/> TCJ-A150-A74-A	150 × 150 × 150	5.5	2000	Aluminum alloy
<input type="checkbox"/> TCJ-A150-A74-M	150 × 150 × 150	4.0	2000	Magnesium alloy
<input type="checkbox"/> TCJ-A160-A74-A	160 × 160 × 160	6.5	2000	Aluminum alloy
<input type="checkbox"/> TCJ-A160-A74-M	160 × 160 × 160	4.6	2000	Magnesium alloy
<input type="checkbox"/> TCJ-A200-A74-A	200 × 200 × 200	8	1000	Aluminum alloy
<input type="checkbox"/> TCJ-A200-A74-M	200 × 200 × 200	5.6	1000	Magnesium alloy
<input type="checkbox"/> TCJ-A250-A74-A	250 × 250 × 250	13.5	650	Aluminum alloy
<input type="checkbox"/> TCJ-A250-A74-M	250 × 250 × 250	9.5	650	Magnesium alloy
<input type="checkbox"/> TCJ-A300-A74-A	300 × 300 × 300	20	400	Aluminum alloy
<input type="checkbox"/> TCJ-A300-A74-M	300 × 300 × 300	14	400	Magnesium alloy
<input type="checkbox"/> TCJ-B150-A74-A	150 × 150 × 150	3.5	2000	Aluminum alloy
<input type="checkbox"/> TCJ-B150-A74-M	150 × 150 × 150	2.5	2000	Magnesium alloy
<input type="checkbox"/> TCJ-B160-A74-A	160 × 160 × 160	4.0	2000	Aluminum alloy
<input type="checkbox"/> TCJ-B160-A74-M	160 × 160 × 160	2.8	2000	Magnesium alloy
<input type="checkbox"/> TCJ-B200-A74-A	200 × 200 × 200	10	2000	Aluminum alloy
<input type="checkbox"/> TCJ-B200-A74-M	200 × 200 × 200	7	2000	Magnesium alloy
<input type="checkbox"/> TCJ-B250-A74-A	250 × 250 × 250	20	1000	Aluminum alloy
<input type="checkbox"/> TCJ-B250-A74-M	250 × 250 × 250	14	1000	Magnesium alloy
<input type="checkbox"/> TCJ-B300-A74-A	300 × 300 × 300	20	600	Aluminum alloy
<input type="checkbox"/> TCJ-B300-A74-M	300 × 300 × 300	14	600	Magnesium alloy

Type A

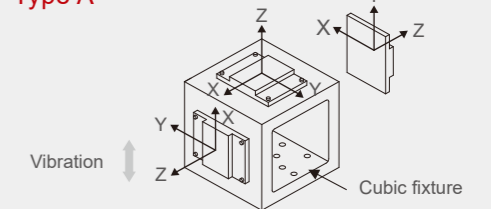

Type B

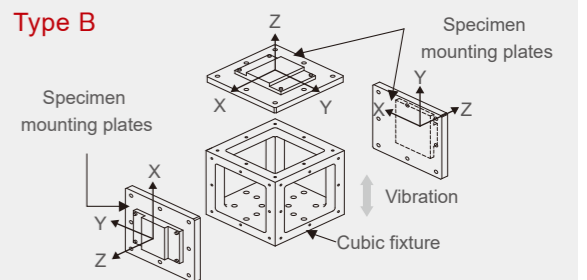

Type A

Type B

Environmental Test Systems

Chamber for Vertical Excitation

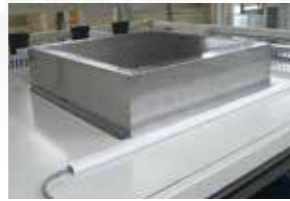

Inner pressure regulator: Reduces internal pressure fluctuation caused by vibration (standard equipment)

Model: Syn-3HA-40-V

Internal dimensions	W 1000 × D 1000 × H 1100 mm
Temperature range	-40°C to +150°C
Humidity range	20% to 95% RH
Temperature pull-down time	+20°C → -40°C In 60 minutes (Curve gradient)
Temperature heat-up time	-40°C → +150°C In 90 minutes (Curve gradient)

Docking image of combined systems

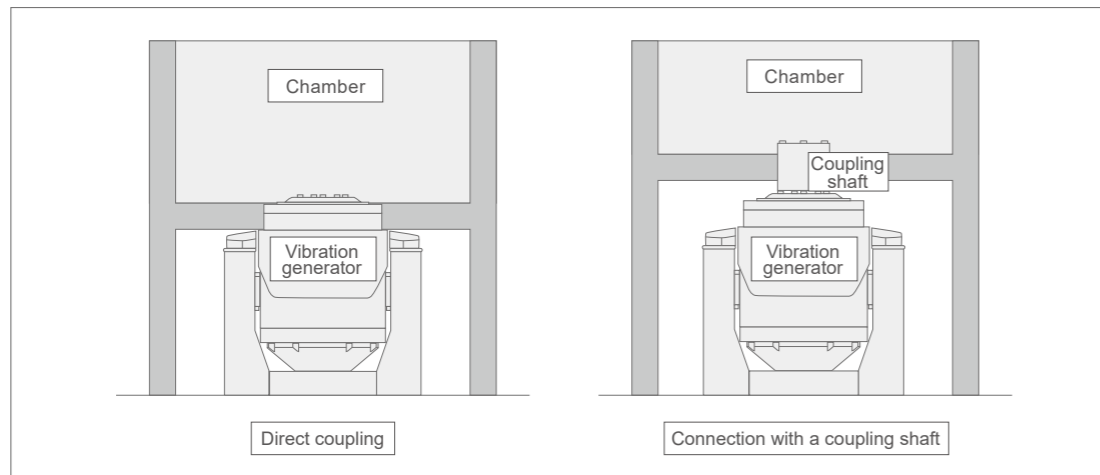

Model: Syn-6HW-30-V

Internal dimensions	W 1800 × D 1900 × H 1500 mm
Temperature range	-30°C to +80°C
Humidity range	30% to 95% RH
Temperature pull-down time	+45°C → -30°C In 35 minutes (Curve gradient)
Temperature heat-up time	-30°C → +80°C In 25 minutes (Curve gradient)

Environmental Test Systems

Chamber for both Vertical and Horizontal Excitation

Horizontal slip table combined with vibration test system. Combining a rail support for horizontal movement and a lift support for vertical movement, this chamber allows combined tests for both vertical and horizontal axes.



Vertical use



Horizontal use

■ Rail and lift support



↔ Horizontal use
↕ Vertical use

Model: Syn-3HA-70-VH

Internal dimensions	W 1000 × D 1000 × H 1000 mm
Temperature range	-70°C to +180°C
Humidity range	20% to 98% RH
Temperature pull-down time	1°C/minutes or more (Curve gradient)
Temperature heat-up time	2°C/minutes or more (Curve gradient)



Watch the YouTube video

Environmental Test Systems

Chamber options for both vertical and horizontal excitation

Optional crane

Adding a dedicated crane allows for the safe and simple loading and unloading of test specimens.



Optional crane and observation door

The vertical base can be attached and detached using the optional crane with the head expander staying mounted on the vibration generator. In addition, operator-friendly features are included, such as an observation door, body-suspension automatic-adjustment mechanism, etc.



Side window

A side window allows chamber-combined docking with the specimen attached to the shaker during vertical excitation.



Cable bear

The cable carrier promotes a safe work environment by allowing cables and water pipes to be held together.



Environmental Test Systems

Chamber for Multi-Axis Excitation

Temperature and humidity chamber for multi-axis vibration test system. The time needed to reconfigure for testing in each axis is eliminated, reducing total test time.

2-axis



Model: Syn-4HA-40-M

Internal dimensions	W 1200 × D 1200 × H 1000 mm
Temperature range	-40°C to +150°C
Humidity range	20% to 98% RH
Temperature pull-down time	+20°C → -40°C In 80 minutes (Load condition: combined + aluminum 60 kg)
Temperature heat-up time	-40°C → +150°C In 80 minutes (Load condition: combined + aluminum 60 kg)

3-axis



Model: Syn-3HA-40-M

Internal dimensions	W 1000 × D 1000 × H 1000 mm
Temperature range	-70°C to +180°C
Humidity range	20% to 98% RH
Temperature pull-down time	+20°C → -70°C In 40 minutes (Curve gradient)
Temperature heat-up time	-70°C → +180°C In 40 minutes (Curve gradient)

Prefabricated Chamber for Large Specimens

Large-sized specimens can be tested with a chamber combined test in both the vertical and horizontal axes.



Model: Syn-6HA-40-VH

Internal dimensions	W 4000 × D 2000 × H 2500 mm
Temperature range	-40°C to +120°C
Humidity range	30% to 95% RH
Temperature pull-down time	+20°C → -40°C In 120 minutes (Curve gradient)
Temperature heat-up time	-40°C → +150°C In 150 minutes (Curve gradient)

Docking image of combined systems

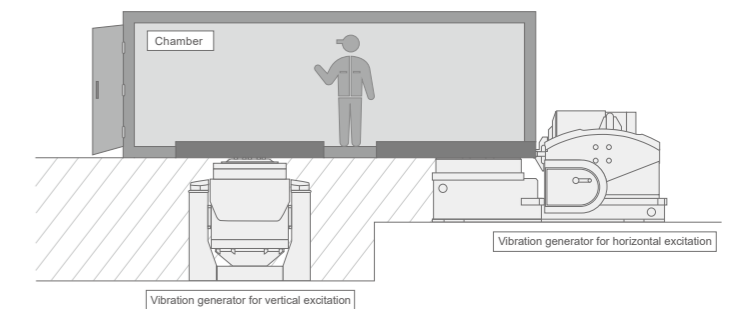

Chamber controller display panel

■ 8.4-inch touch panel

Clear display of information and buttons on the 8.4-inch touch-panel. A clean and unambiguous way to see all of the information needed.



■ Program editable in PC

Tests can be set up using a spreadsheet. Programs use the standard CSV file format.

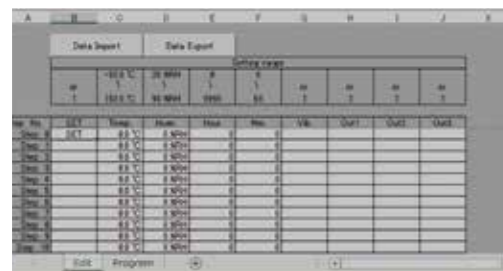

System monitor (option)

The controller connects to the system monitor using Ethernet. The test status of both vibration generator and chamber can be monitored remotely.



■ Program selection

Up to 100 programs can be stored in memory. Program selection is straightforward.



■ Program confirmation

Test progress can be viewed using tabular and graphical displays.

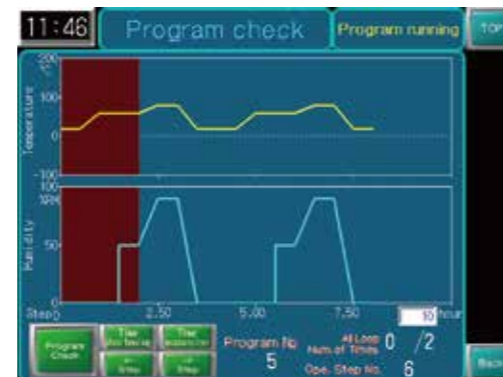

Integrated control system (option)

Vibration generator, chamber and other equipment can be controlled from one place.

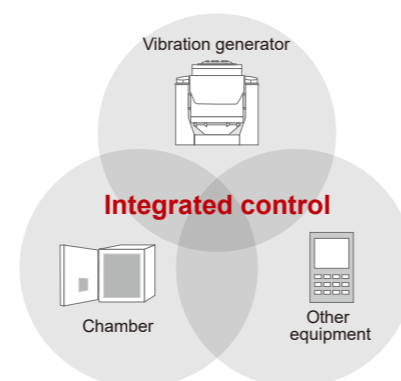

Many options are available for simplified operation, such as different door positioning and observation window locations.

■ Observation door

An observation door enables monitoring of the test specimen.



■ Infrared irradiation

Car instrument panel, door, bumper, or body sections can be tested.



■ Ceiling observation window

A ceiling observation window allows full visibility of the vibration test.

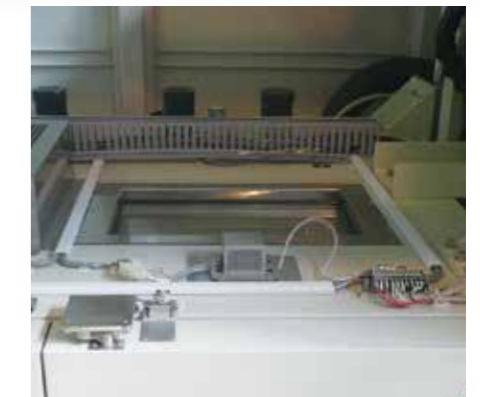

■ Safety measures for fuel cell tests

Please consult with us on safety measures for fuel cell tests specific to each application.

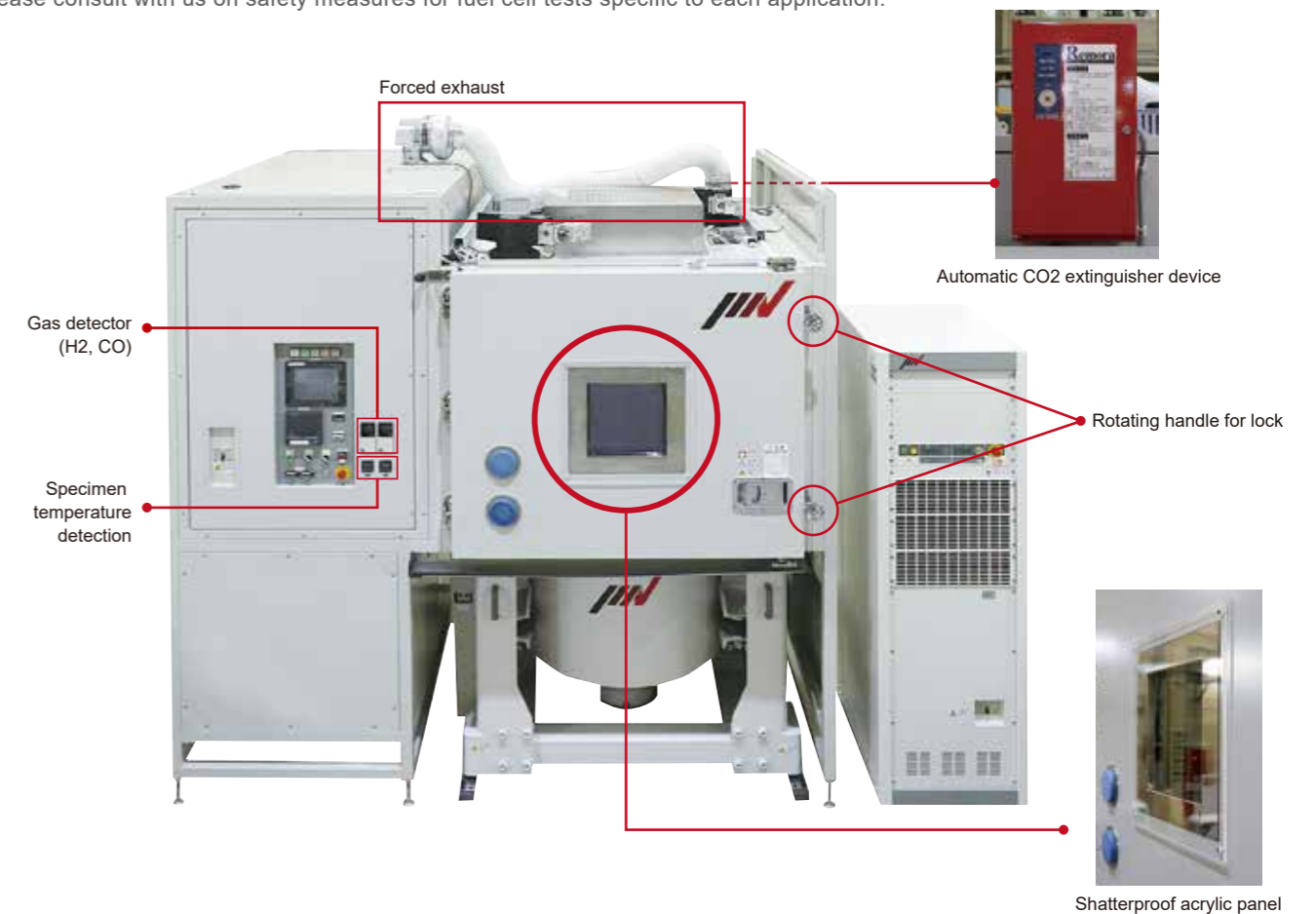

Optional Units

Duct

A newly upgraded duct is standard equipment for every system. No operation needed for direction change between vertical and horizontal. Space behind the shaker is minimized.

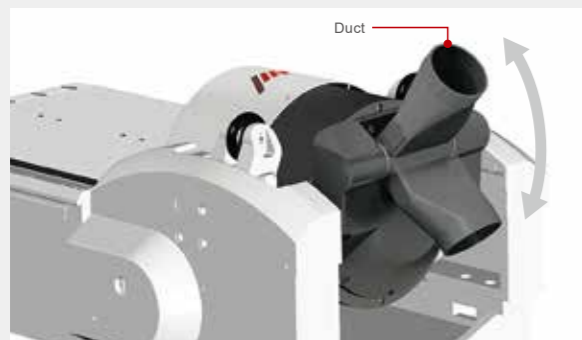

Cooling ducting

The standard arrangement for air-cooled systems is to install the blower outside the work area. Ducting inlet air from outside eliminates the changes in ambient pressure and temperature caused by the cooling air flow.



Soundproof enclosure

A soundproof enclosure for the cooling blower reduces noise in installations where the blower cannot be placed outside the work area.



inside

Drive bar adapter with diagonal bolt access

The method for fastening a drive bar to a slip table was simplified in response to customer feedback. Usability has been improved and torque adjustment for bolts made easier.

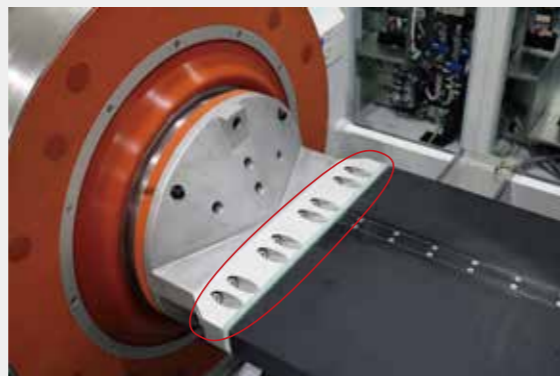

Combined option with high thermal insulation

Choosing the option of directly combining with the A-series utilizes a newly-designed structure with high thermal insulation. Improved temperature uniformity inside the chamber reduces the effects of condensation down to 1/5.



*Only for A30, A45, A65, A74

Optional built-in vibration controller

PC, display and keyboard for the vibration controller can be incorporated into the power amplifier for extra space-saving. The keyboard can be stored away when not in use.

*Display size is 17 inch
*Keyboard with numeric keypad



*Only for A11, A22

Videos

Sine sweep test using the A-series

Vibration Test Systems

This is a video of the Sine sweep test using the A-series. The sweep test is a test that generates vibration while gradually changing the frequency.



Multi sweep Sine test using the A-series

Vibration Test Systems

This is a video of the Multi Sweep Sine test using the A-series. The Multi Sweep Sine test is a test in which sinusoidal excitation of multiple frequencies is performed at the same time.



Random test using the A-series

Vibration Test Systems

This is a video of the Random test using the A-series. The Random test is a test of irregular vibration.



Shock test using the A-series

Vibration Test Systems

This is a video of the Shock test using the A-series. The Shock test is a test that evaluates the durability of a product by exerting a large, sudden force on it.



Environmentally-friendly vibration systems

eco-shaker

Vibration Test Systems

IMV's eco-shaker uses a patented solution called ISM to automatically reduce noise, energy consumption and heat generation. Take a look to see how quiet the eco-shaker can be.



Basic units used for vibration test

There are four important units for a vibration test. Force [N], Acceleration [m/s²], Velocity [m/s], and Displacement [mm peak-to-peak (p-p)]
The force "F" required to give an object of mass, "m" acceleration "A" is:

$$F = mA$$

	SI units	Gravitational units
F: force	[N]	[kgf]
m: mass	[kg]	[kg]
A: acceleration	[m/s ²]	[G]

That is to say, when a mass of 1 kg is accelerated to an acceleration of 1 m/s² the required force is 1 N. Gravitational acceleration "G" equals to 9.8 m/s².

To describe vibration, frequency and vibration level need to be specified. Vibration is a form of movement with a consequent relationship between acceleration, velocity and displacement. To describe vibration level, any of these units can be used. Here are the relationships between each of the units.

We have an object moving in a sine wave.

The displacement is:

$$D = D_0 \sin \omega t$$

The velocity is obtained by differentiation of the displacement. Therefore

$$V = \frac{dD}{dt}$$

$$V = \omega D_0 \cos \omega t$$

The acceleration is obtained by differentiation of the velocity. Therefore

$$A = \frac{dV}{dt}$$

$$A = -\omega^2 D_0 \sin \omega t$$

As we substitute

$$\omega = 2\pi f$$

We have formulae indicated only in amplitude:

$V = \omega D = 2\pi f D$	D: Displacement	[m ^{0-p}]
$A = \omega^2 D = (2\pi f)^2 D$	V: Velocity	[m/s]
	A: Acceleration	[m/s ²]

The following diagram shows waveforms for displacement, velocity and acceleration.

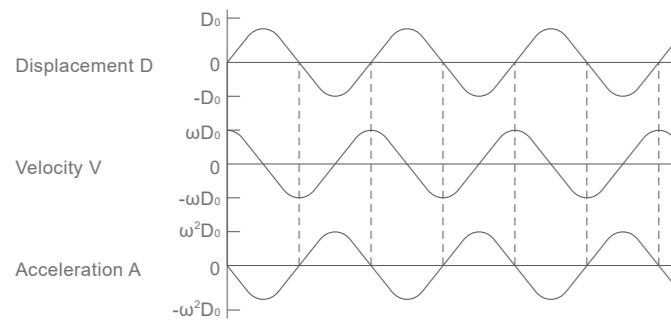

We get the formulae below by transforming the above formulae.

$$f = \frac{A}{2\pi V}$$

$$A = \frac{V^2}{D}$$

$$V = 2\pi f D$$

$$D = \frac{A}{(2\pi f)^2}$$

In the field of vibration test, we use mm p-p for peak to peak displacement.

Therefore

$$D = \frac{d}{2000}$$

is substituted into all of the above formulae

$f = \frac{A}{2\pi V}$	f: Frequency [Hz]
$A = \frac{(2\pi f)^2 d}{2000}$	A: Acceleration [m/s ²]
$V = \frac{2\pi f d}{2000}$	V: Velocity [m/s]
$d = \frac{2000A}{(2\pi f)^2}$	d: Displacement [mmp-p]

The following is an example

[ex] i) $f = 50$ [Hz], $d = 2$ [mmp-p]

$$V = \frac{2\pi f d}{2000} = \frac{2 \times \pi \times 50 \times 2}{2000} = 0.314 \text{ [m/s]}$$

$$A = \frac{(2\pi f)^2 d}{2000} = \frac{4 \times \pi^2 \times 50^2 \times 2}{2000} = 98.7 \text{ [m/s}^2\text{]}$$

ii) $A = 100$ [m/s²], $V = 0.5$ [m/s]

$$f = \frac{A}{2\pi V} = \frac{100}{2 \times \pi \times 0.5} = 31.8 \text{ [Hz]}$$

$$d = \frac{2000V^2}{A} = \frac{2000 \times 0.5^2}{100} = 5 \text{ [mmp-p]}$$

About [dB]

We use "dB" as a unit when describing the proportional relationship of physical quantities. Especially, in cases where one value is thousands or millions times a multiple of a reference value, then we use the logarithmic scale "dB" instead of a linear scale. This makes the values more sensible and is an industry standard practice.

"dB" is expressed by the following

$$a = 20 \log \frac{A_1}{A_0} \text{ [dB]}$$

A₁ = Comparison value
A₀ = Reference value

One million times is:

$$a = 20 \log \frac{1,000,000}{1} = 120 \text{ [dB]}$$

Not only does dB reduce the number of digits (smaller numbers to handle) but it also simplifies calculations. For example, adding 25 dB and 30 dB makes 55 dB, but if you do it in a linear way:

$$25 \text{ [dB]} = 20 \log A \quad A = 10^{\frac{25}{20}} = 17.78$$

$$30 \text{ [dB]} = 20 \log B \quad B = 10^{\frac{30}{20}} = 31.62$$

$$A \times B = 17.78 \times 31.62 = 562.3 = 20 \log 562.3 = 55 \text{ [dB]}$$

Now you see you can use addition instead of multiplication by using "dB". That is to say, it is very easy to calculate by using "dB".

The following is a conversion table for "dB" and multiples.

dB	0	0.1	1	3	6	10	20	30	40	60
Multiple	1	1.01	1.12	1.41	2.0	3.16	10	31.6	100	1000

dB	0	-0.1	-1	-3	-6	-10	-20	-30	-40	-60
Multiple	1	0.99	0.891	0.709	0.501	0.316	0.1	0.0316	0.01	0.001

Use of a logarithmic graph

We often use a logarithmic graph when we need to plot data for vibration testing or other physical phenomena.

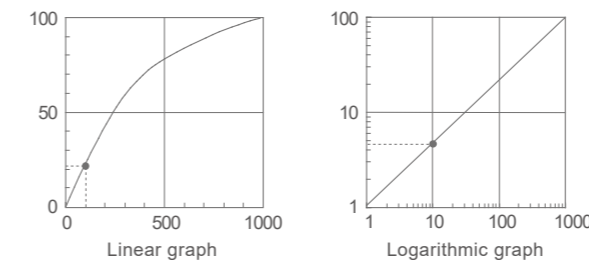

On the linear graph, we can read 20 for Y when X is 100. But we can hardly read Y when X is 10 or 1, whereas on the logarithmic graph, we can read the value even if it is 1/100 or 1/1000 of the maximum value. We use a logarithmic graph for such a benefit.

Sine test graph

We often use the graph below when running a Sine vibration test. This is a log-log graph that was discussed above. Asymptotes of constant displacement, velocity and acceleration are shown. Here is an example of an asymptote of constant velocity. From the formulae we learned before:

$$A = 2\pi f V$$

A: Acceleration
f: Frequency
V: Velocity

From this equation we can read that acceleration A is increased 10 times when frequency f is also increased 10 times. On the graph below, we see that the acceleration increases to 100 m/s² from 10 m/s² as the frequency increases from 10 Hz to 100 Hz.

In the case of constant displacement

$$A = (2\pi f)^2 D$$

D: Displacement

The equation shows that acceleration A is increased by 100 (10²) times when the frequency f is increased by 10 times, acceleration being proportioned to the second power of displacement. On the graph below, we can read that the acceleration increases to 100 m/s² from 1 m/s² as the frequency increases to 10 Hz from 1 Hz.

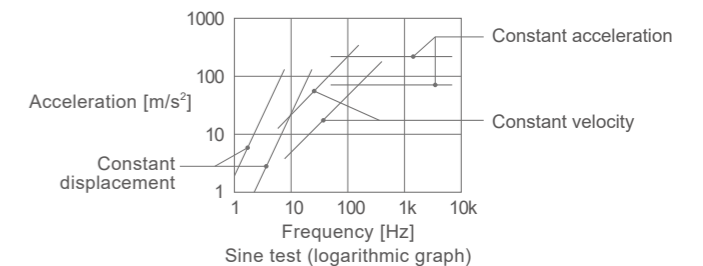

The graph shows the asymptotes when velocity or displacement stays constant.

Vibration insulation for a vibration generator

When using a vibration generator, the vibration is transmitted to the building and other facilities through the floor.

Particularly in the frequency range of 2 Hz to 20 Hz, even a small proportion of vibration from the vibration generator can have a large effect on buildings because they have their own resonances in this frequency range.

Therefore, a vibration generator needs a vibration isolation system.

The following shows some examples.

1) No insulation

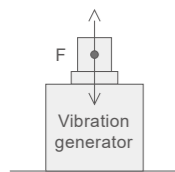

F: Force

All the force generated by the vibration system is transmitted into the floor. This may excite resonances in the building and adjacent facilities. The vibration generator itself may sometimes jump up and down.

2) Body suspension

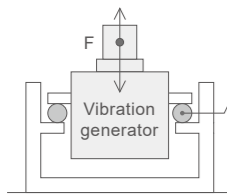

Air springs

IMV uses this method of vibration isolation except in the case of the small, compact shaker range. This may limit a shaker system's maximum displacement when the operating frequency is low. See "Limitation of maximum displacement"

3) Bottom suspension

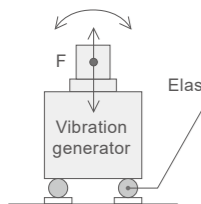

Elastic objects or air springs

This has a similar effect of vibration isolation but it can also cause lateral motion at low frequency.

4) Isolated foundation

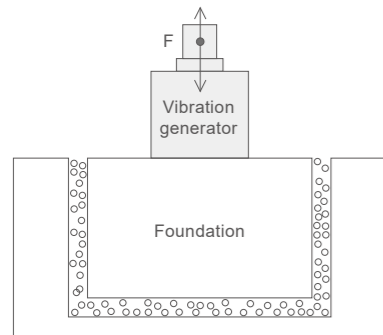

This is the best method of vibration isolation. Generally, the mass of the foundation block should be at least ten times heavier than the rated force of the system. Typically, the mass of the foundation should be twenty times heavier. If you are interested in this method of isolation, please contact IMV.

Limitation of maximum displacement

There are several methods for vibration isolation. All of these ways create limitations in maximum displacement.

In body isolation, the vibration generator body reacts against the movement of the specimen.

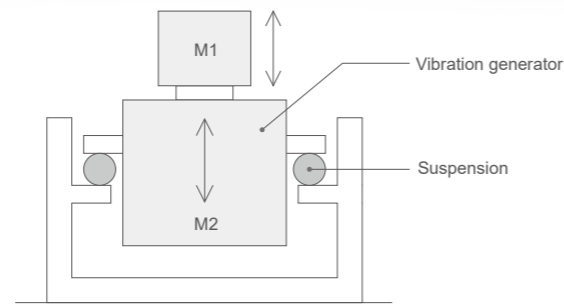

This will cause the vibration generator body to be excited by the reaction force. If the shaker excitation frequency is 2-7 Hz, this may coincide with the resonant frequency of the armature suspension system and the body suspension system. The armature and body motion could be almost in "anti-phase", resulting in the absolute value of the available armature displacement becoming severely limited. Typically only 10 mmp-p displacement is available from a 51 mmp-p-rated vibration generator.

If using an "isolated foundation", the effective mass of the foundation plus vibration generator body could be much heavier than specimen + armature assembly. Therefore, limitation for the available displacement becomes negligible.

Noise control

When a vibration test system is installed, noise is an important consideration. There are several sources of noise, such as excitation noise, suction noise (for air-cooled systems), blower noise, blower exhaust noise, cooling fan noise of the power amplifier, etc.

The shaker excitation noise might exceed 100 dBA at a typical maximum acceleration of 980 m/s². The suction noise is about 90 dBA, and blower noise + blower exhaust noise is about 80 dBA. However, these figures can differ depending on the shaker model.

1) Installing the blower outside the room

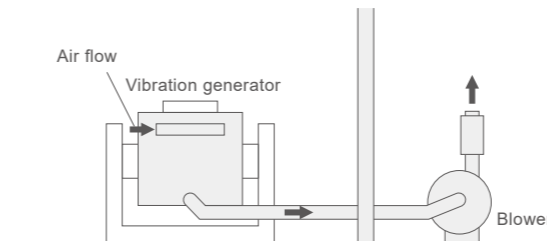

This is a common and straightforward method. The blower noise and the blower exhaust noise are reduced in the test area. However, this method doesn't change the suction noise or the excitation noise of the vibration generator. *The blower cannot be installed outdoors.

2) Soundproof box

A. Vibration generator and blower

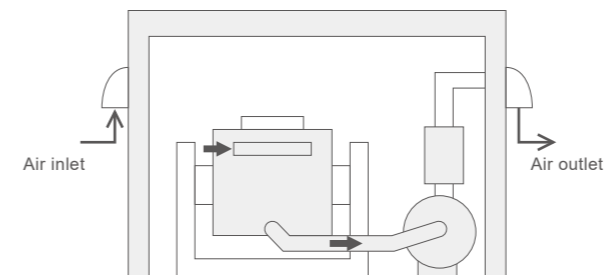

This method reduces the excitation noise and the blower noise. *While the blower is stopped, we recommend taking measures to prevent air backflow.

B. Vibration generator only (blower outside the room)

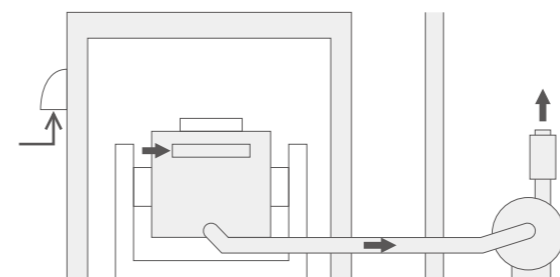

The excitation noise and the air inlet noise are lowered. Placing the blower outside the room is recommended. *The blower cannot be installed outdoors.

C. Soundproof box only for the blower

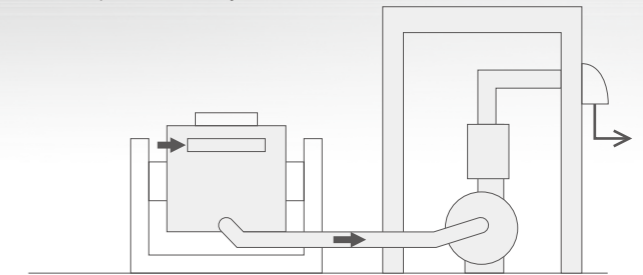

The blower noise is reduced. This method doesn't change the suction noise or the excitation noise of the vibration generator. *While the blower is stopped, it is advisable to take measures against air backflow.

3) Concentrated suction design

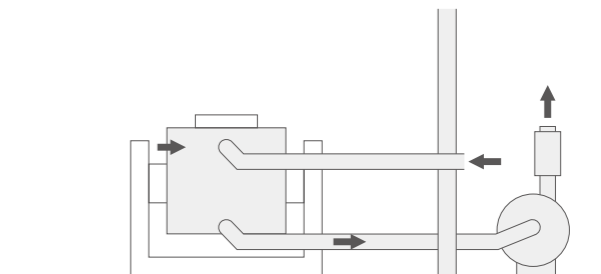

The suction noise of the vibration generator falls by about 5 dB. The main purpose of concentrated suction is to take air from the outside without using the air in the room to cool the shaker (typically used for clean rooms, etc.). *The blower cannot be installed outdoors.